

Memory in interpreting

Turković, Martina

Master's thesis / Diplomski rad

2013

Degree Grantor / Ustanova koja je dodijelila akademski / stručni stupanj: **Josip Juraj Strossmayer University of Osijek, Faculty of Humanities and Social Sciences / Sveučilište Josipa Jurja Strossmayera u Osijeku, Filozofski fakultet**

Permanent link / Trajna poveznica: <https://um.nsk.hr/um:nbn:hr:142:258640>

Rights / Prava: [In copyright](#)/[Zaštićeno autorskim pravom.](#)

Download date / Datum preuzimanja: **2024-11-28**



FILOZOFSKI FAKULTET
SVEUČILIŠTE JOSIPA JURJA STROSSMAYERA U OSIJEKU

Repository / Repozitorij:

[FFOS-repository - Repository of the Faculty of Humanities and Social Sciences Osijek](#)



SVEUČILIŠTE JOSIPA JURJA STROSSMAYERA U OSIJEKU

FILOZOFSKI FAKULTET

Diplomski studij engleskog i njemačkog jezika prevoditeljski smjer

Martina Turković

„Memory in interpreting“

Diplomski rad

Mentor: izv.prof. dr. sc. Marija Omazić

Osijek, 2013.

Table of contents:

1. Introduction.....	1
2. Interpreting.....	2
2.1 Consecutive interpretation	2
2.2. Simultaneous interpretation.....	3
3. Memory.....	4
3.1. The foundation of memory models.....	5
3.2. Atkinson and Shiffrin's memory model.....	6
3.3 Hitch and Baddeley's working memory model.....	8
3.4.Encoding, storing and retrieving memories.....	10
4.Gile's Effort Model.....	12
5. Cowan's memory model.....	14
6. Daro and Fabbro's simultaneous interpretation model.....	18
6.1 Overview of long-term memory.....	18
6.2 Valeria Darò and Franco Fabbro's memory model.....	19
6.3 Interpreting strategies.....	22
6.3.1. Waiting and stalling.....	23
6.3.2. Chunking or segmentation.....	23
6.3.3. Anticipation.....	24
6.3.4. Meaning-based and transcoding strategy.....	24
6.4 Memory training.....	25
6.4.1. Retelling a story in the Source Language.....	26
6.4.2. Mnemonics.....	28
7. Determiners of good interpreters.....	30
7.1. Cognitive abilities.....	31
7.2 Formal training.....	32
7.3 Coping with stress.....	33
8. Conclusion.....	36

Abstract

Interpreting as a skilled profession is explained, as well as its two main types consecutive and simultaneous interpreting. Memory as a complex function of the human brain is explored as well as its features. After describing the complexity of memory, a theoretical framework of different cognitive memory models is provided starting with its foundations and then further exploring the following models: Atkinson and Shiffrin's memory model, Hitch and Baddeley's working memory model, Gile's Effort Model, Cowan's memory model, and Daro and Fabbro's simultaneous interpretation model. Apart from explaining the different models as proposed by cognitive psychologists the paper also further explains certain features of encoding, storing and retrieving memories as well as giving an overview of the functions of long-term memory. Interpreting strategies are provided to introduce how interpreters deal with their task. Memory enhancement is defined and memory examples are given. In the end determiners of good interpreters are presented such as coping with stress and formal training.

Key words: interpreting, memory, cognition, theory, simultaneous interpreting, consecutive interpreting

1. Introduction

This paper explains the implications of memory on the interpretation process. It provides the theoretical framework of consecutive and simultaneous interpretation as well as six memory models presented in cognitive psychology. It gives an overview of five different memory models that attempt to explain the way in which the human brain stores, encodes and retrieves information. It also explains the way in which an interpreter uses the different functions of these diverse memory models. The aim of the paper is to contribute to the comprehension of cognitive processes of the interpreter, which include the capacity of working memory, the ability to control the focus of attention on the process and other factors such as coping with stress and formal training.

2. Interpreting

The meaning of the verb can be derived from its etymology which states that “to interpret” from the Latin word „*interpretari* means "explain, expound, understand," and from „*interpretas*” “agent, translator,”¹ So the meaning of the word could be understood as “person who explains, expounds, understands”. The role of the interpreter is hence to explain what other people have difficulty understanding.

An interpreter is a person who orally transmits the message presented in the source language (SL) into the target language (TL). The task of the interpreter is to convey the meaning of the message. One of the main differences between interpretation and translation is that interpreting is performed verbally and it is done immediately in the ‘here and now’ “for the benefit of people who want to engage in communication across barriers of language and culture.” (Pöchhacker 2004: 25). Since interpreting takes places immediately, the output of the interpreters is immediately assessed by colleagues and clients. The interpreters’ text is usually shorter than the source speech. Due to this immediacy factor which ultimately leads to stress “linguistically less well-formed utterances and a less precise rendering of the source text are acceptable” (Christoffels 2004: 8).

The processes of interpreting and translating are fairly different and they inevitably involve different cognitive processes. This paper focuses on cognition in the process of interpretation.

2.1 *Consecutive interpretation*

Only recently with the development of technologies (the booth, headphones, microphones) which would enable simultaneous interpretation, has it become important to distinguish between the two main types of interpretation.

In consecutive interpreting the speech is fragmented into several parts during which the interpreter has the possibility of taking notes. The duration of a fragment or speech segment is perceived differently. Pöchhacker (2004: 18) states that” consecutive interpreting does not presuppose a particular duration of the original act of discourse, it can be conceived of as a continuum which ranges from the rendition of utterances as short as one word to the handling of

¹ *Online Etymology Dictionary- Web, 10 March 2013*

entire speeches, or more or less lengthy portions thereof'. However the European Commission considers skilled interpreters those, who can consecutively interpret segments of about 10 minutes.

Consecutive interpreting puts a high demand on the LTM of the interpreter since rendering the message is done after a certain period of time, where the interpreter has to rely on his/her memory and notes.

Simultaneous interpretation is starting to take over in the modern world, but consecutive remains a technique used for events such as business dinners, field trips, social gatherings as well as the court, in diplomacy and healthcare.

2.2. Simultaneous interpretation

Simultaneous interpretation (SI) is a highly complex cognitive task as it involves simultaneously listening to a speech in the SL and interpreting it into the TL.

This form of interpreting is considered to be a demanding task because a simultaneous interpreter has to listen, understand, plan and speak at the same time. The interpreter listens to new speech while concurrently storing pieces of speech in his or her memory and producing the target language speech without control over the source speech rate or the content. This form of interpreting uses cognitive processes, such as working memory and the attention system to their maximum. Pöchhacker (2004: 19) defines simultaneous interpreting as “spoken language interpreting with the use of simultaneous interpreting equipment in a sound-proof booth’.”

Since simultaneous interpreting puts a strain on the cognitive functions of the interpreter and is quite demanding in terms of stress, interpreters usually work in pairs and take turns every 30 minutes. Approximately 4000 words are uttered in the mentioned 30-minute turn. During SI the input speech rate is determined by the speaker, which consists of about 100 to 200 words per minute. The information which the interpreter fails to hear and render in the TL is inevitably irretrievable. This puts a high amount of stress on the interpreter.

Performed by experts, it is a task which requires flexibility and efficient distribution of attention in a way which will lead towards a fluent delivery of the target-language counterpart of a source-language speech. Studies and research aim to understand the tensions between maintaining a balanced speech output and an appropriate TL representation which would be semantically and pragmatically correct.

Simultaneous interpreting is a young profession so there is still a lot of research that needs to be done in order of understanding its complexity as well as the different skills required to be successful in conveying the speaker's message. Cognitive psychologists define SI as a "complex human information processing activity composed of a series of interdependent skills" (Gambier et al. 1994:16). There are different cognitive components that influence the interpretation process such as: processing speed, cognitive control, task switching, fluid intelligence, working memory and mental flexibility. This paper will focus mainly on the working memory usage in SI by applying the different memory models as proposed by cognitive psychologists.

3. Memory

This chapter will attempt to explain memory and its functions; provide a theoretical framework for different memory models that were introduced by cognitive psychologists and their application to interpreting.

In order of understanding the impact of memory, and working memory in particular on the interpretation process and interpreters, we must first understand memory itself. The adaptation to the world which surrounds us and our survival depend on "the ability to acquire and to retrieve stored information from memory in order to solve different kinds of problems arising in a complex environment" (Daró 1997: 622). It is important to note "that memory is not a unitary function, but rather a range of multi-modal, interrelated systems which can be functionally independent from each other,..." (Daró 1997: 622). Our cognitive abilities perceive and recognize new and past information in order of learning and retrieving acquired information. The Merriam Webster Online Dictionary defines memory as follows:

- a: the power or process of reproducing or recalling what has been learned and retained especially through associative mechanisms
- b: the store of things learned and retained from an organism's activity or experience as evidenced by modification of structure or behavior or by recall and recognition²

In cognitive psychology several models of memory are distinguished. All of which attempt to explain one of the world's biggest mysteries, the human brain, its functions and the way we

² *Merriam-Webster Online Dictionary, Web 7 March 2013*

acquire, store and process information. The least is known about its various functions as well as the mental processes which occur within it. In order of shedding some light on cognition and its products several models of memory have been proposed.

3.1. *The foundation of memory models*

Cognitive psychology is a recently developed branch of psychology that investigates the way in which the brain acquires and uses information. Seeing as cognitive psychology has been developed in the course of the last 200 years, the theories about different models of memory have also started to evolve recently, about a hundred years ago. The findings about memory and the models which assume to explain it are still changing and progressing.

Let us take an example to start understanding the complexity of our memory. Suppose you are at home when you receive a phone call and the person you are talking to gives you the telephone number of an important client “091/523 1572”. At the given moment you are in lack of a paper and pen so you attempt to remember the number until you can find them. In order of holding on to the information for a short period of time you would need to use what was first named by William James (1890) as *primary memory*. You would probably also use a certain technique in order of remembering the digits. A way of holding on to the information would be to divide the digits into “091” the code of the phone company, “523” and possibly “1572”. This would enable you to ultimately write down the number once you get hold of a pen and paper. Miller (1956) argued “that the span of immediate memory was, typically, 7 plus or minus 2” (Collins et al. 2004: 157). Miller called a sequence of digits represented in this way “chunks”. Now imagine you use that number on an everyday basis and learn it by heart enabling you to use it for a longer time. James named this type of memory, which can be accessed for a longer time period *secondary memory*.

These two classifications of memory were explained by Gambier et al. (1994: 141) as “one of the information forming the focus of current attention and occupying the stream of thought, and the other for knowledge of events or facts belonging to former states of mind” which has been the first attempt to subcategorize different memory types that would later become known as short term and long term memory.

3.2. *Atkinson and Shiffrin’s Memory Model*

James's division into primary and secondary memory was one of the first efforts to make not only a distinction between different memory types but also to shed light on the human cognitive processes. This division served as a basis for more complex memory models, one of which is Atkinson and Shiffrin's Three-store model.

Atkinson and Shiffrin (Collins et al. 2004) use James' dualistic approach and divide memory into a short-term memory store (STS) and a long-term memory store (LTM). However they also add a further subcategory which processes sensory information and that serves as a primitive storage for information. As depicted in Figure 1 the sensory store registers "incoming signals, holding them for a second or two in a primitive form which is readily disrupted by further signals in the same sensory channel" (Collins et al. 2004: 160). This store serves as a form of temporary store for visual, auditory and haptic information, which channels this input into the STS. "The function of short-term memory is to provide a means of controlling and enhancing, via rehearsal and coding strategies (such as chunking), the information that makes it into long-term memory."³ As *Figure 1* illustrates, the information which enters the STS has to undergo a number of different control processes in order of going into the LTS. The first is the rehearsal process in which the data has to be altered into a rehearsable structure. The second step is to code the information by regaining the necessary data from the LTS. The last two processes are making decisions and using strategies to retrieve information. According to their model in order of storing information in the LTS, it has to go through all of the mentioned control processes, by which we can assume that the information is otherwise lost.

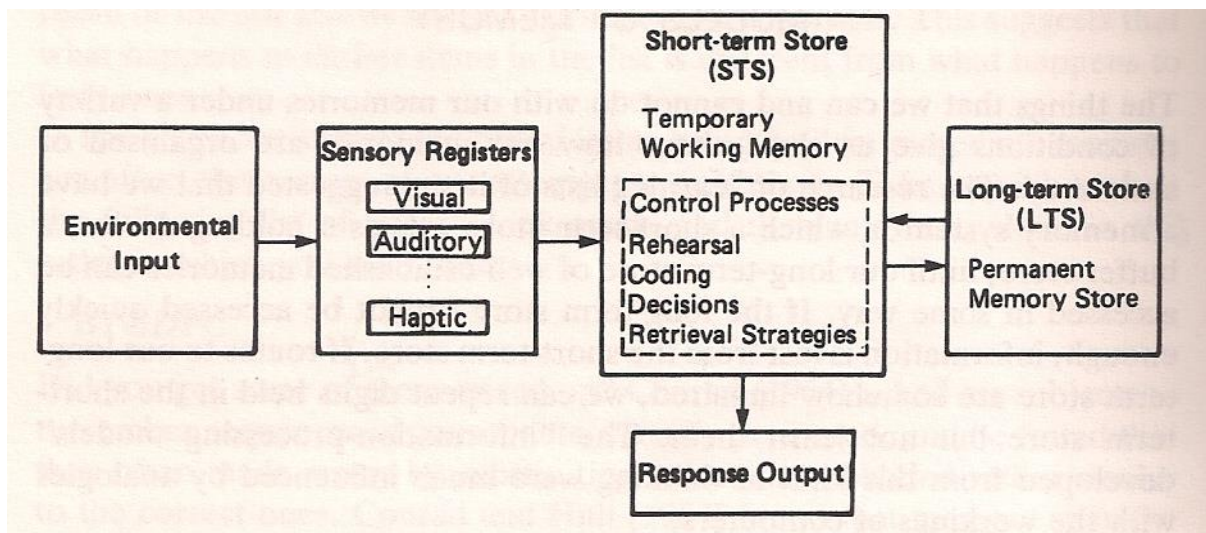

³ „Working memory“ - <http://www-psych.stanford.edu/~ashas/Cognition%20Textbook/chapter6.pdf> Web 8 March 2013

Figure 1 Atkinson and Shiffrin's model of memory

Their model, although more complex than previous models, suggests that both the sensory and short-term store are merely a mediator, which furthers information into the only permanent subcategory, the long-term store. Even though their model is referred to as *the modal model of memory*, which means it is the mostly quoted memory model, it clearly fails to explain certain features. Two obvious problems arose, the first was the chronological order by which the information passed through the sensory and short-term stores into the long-term store and the second was the formation of a unitary short-term store.

Experiments on amnesic patients who had problems accessing long-term memory but were completely capable of using their short-term stores as well as patients with brain damage who had problems using their STS but were capable of regaining information from the LTS, led to the conclusion that the way in which information is processed doesn't necessarily have to be in a sequence. If it is possible to access information from the LTS when the STS isn't functioning properly and vice versa, the conclusion is that the two stores are not linked in the way Atkinson and Shiffrin suggest. Their Three-store model "depicted a limited capacity buffer or store that could hold a small number of items, served as the gateway to a capacity-unlimited long-term store, relied largely on acoustic coding, and was always subject to extremely rapid decay unless continuous rehearsal and recycling of information occurred" (Posner 1998: 686).

Failure to explain the above mentioned features led to fractioning the short-term store into several subcomponents, one of which was working memory "which combined storage with ongoing processing" (Timarova 2009: 2). Even the use of the term "working" suggested that the STS was not merely a passive store which serves as an entrance for information into the LTM. Baddeley and Hitch (1974) therefore proposed a new, more detailed model of memory.

3.3 Hitch and Baddeley's working memory model

To explain the missing elements of Atkinson and Shiffrin's modal memory model, Hitch and Baddeley (Baddeley and Hitch 1974, Baddeley 1996 and Baddeley 2000) proposed what is still considered one of the most significant models of working memory.

Their model (1974) uses the term working memory rather than STM. This shift in terminology adds value to this particular storage. The role of STM in the modal model was fairly

small; one could argue that it was like a ship, simply carrying information from one coast to the next. As shown in *Figure 2* Baddeley and Hitch propose a model which incorporates a central executive component, which is in a way a supervisor for the two “slave subsystems- the *phonological loop* and the *visuospatial sketchpad*” (Timarova 2009: 3).

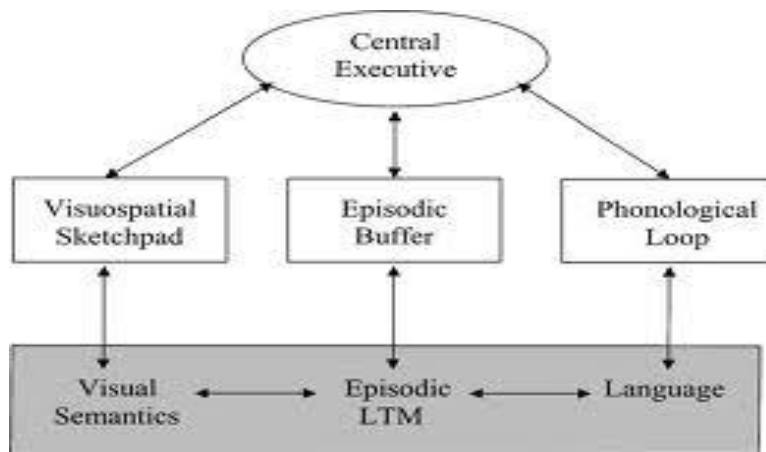

Figure 2 Hitch and Baddeley’s Working Memory Model

How did they come to realize that there was a need for segmentation of the STS? Hitch and Baddeley performed an experiment in which the participants were asked to manage two tasks at the same time. The first task was to repeat a list of digits and the second to answer questions e.g. is B followed by A? As the list of words increased the participants needed more time to answer the questions; however they didn’t make more mistakes. The existence of more STS subsystems was therefore proven.

The phonological loop was then further divided by Baddeley (1986) into a phonological store and an articulatory control process. The phonological store is a form of inner ear, which can hold spoken words for 1-2 seconds. Seeing as words occur in two forms, oral and written, the oral information can enter the loop directly, whereas the written must first be converted to a spoken form. Since the phonological loop is the subsystem which is more relevant to the process of simultaneous interpretation, more attention will be put on this particular subsystem in this paper.

The following example will assume to further explain the phonological store. Try to remember the following digits by first reading them and then closing your eyes and trying to memorize the digits, silently. Then after a few seconds, repeat them aloud.

8 9 1 3 4 6 7

While you were reading them in your head you heard your own voice, which is considered to be the phonological loop. The rehearsal process of repeating the digits is the articulatory control process.

Another example which was conducted by Ellis and Hennelly (1980)⁴ can be used to further explain the articulatory loop. “The argument is that the ability to rehearse is linked to the ability to articulate, and so the capacity of the rehearsal system is determined by how long words take to say” (Posner 1998: 688). This can be directly linked to the process of simultaneous interpretation. If for example a language has longer words for digits, which an interpreter is supposed to articulate, the digit span will be shorter. Ellis and Hennelly have conducted their experiment with children who spoke English and Welsh. Since it takes longer to express digits in Welsh than in English, the children had shorter digit spans in Welsh, which means they had recalled less digits in that language.

Another factor that could influence the interpretation process is the word length. Short words are remembered better than longer ones. What causes this feature is the fact that longer words simply take longer to say, causing the memory span to become shorter. There have been various studies of languages which suggest that there is a relationship between speech rate and memory span. The number of words or “chunks” which can be remembered is linked to the amount of time it takes an individual, in this case an interpreter, to pronounce these items. This could mean that if an interpreter usually speaks faster, he or she has a bigger memory span.

The central executive and the episodic buffer are two further systems whose functions need to be explained. The central executive is a coordinating system which is in charge of controlling the cognitive processes. It has the role of bringing together information from different sources, such as the phonological loop, the visuospatial scratchpad and the episodic buffer (added by Baddeley in 2000). It coordinates the slave systems and changes between tasks and strategies of retrieval and switches attention.

The episodic buffer was added by Baddeley in 2000 in order of explaining some missing features. It “serves as a mental workspace which stores processed and integrated information“(Timarova 2009: 5). Information is hence stored temporarily in the episodic buffer and completed by information retrieved from the LTM. This model also makes a difference between fluid and crystallized systems. The fluid systems, which serve as temporary stores, are

⁴ *Working memory, Web 7 March 2013*

the once illustrated in white in Figure 2, whereas the crystallized, whose function is to store knowledge, are presented in grey. The central executive and the episodic buffer stores are bound to be significant for the simultaneous interpretation process. “They are presumably involved in the activation of relevant information in long-term memory, the suppression of irrelevant information, the integration of information in, and the coordination of the different processes during SI.” (Christoffels 2004: 19).

3.4 Encoding, storage and retrieval of information

Memory as well as the models that are trying to explain its complexity are nevertheless abstract and can be difficult to understand. Cognitive psychologists have managed to explain some of its functions by fragmenting it into several components; however memory also comprises several features needed for information to be stored in long-term memory. What is needed for our cognitive system to remember information and be able to access it? The processes that undergo within it have been termed encoding, storing and retrieving. These processes are needed for us to save and use different information in our memories and as such are also relevant to the process of interpretation.

Encoding is the process of changing our cognitive system in a way that will enable us to recall the memories at a later stage. It is “the process by which new incoming information is related to and transformed by pre-existing knowledge structures” (Posner 1998: 689). As a result of encoding some trace remains in our cognitive system. What is encoded is determined by the activity in which we are engaged while trying to comprehend what we see, hear or read. It is interesting to find out what is required for us to create memories and store information. One could argue that the things we encounter every day will be the things our brain remembers. However several experiments by Nickerson and Adams (1979), Morris and Morton (1967) have shown that our memory for everyday objects is minimal. Nickerson and Adams have tested the knowledge of Americans about the features of the penny. Of 20 participants, only a coin collector was capable of remembering the 8 features of the penny. This experiment shows us that more than encounter or exposure to certain things or information is required to be able to encode information. How many features of “a one kuna coin” would you be able to recall? Craik and Lockhart (1972) have tried to explain this by adding the terms “maintenance rehearsal” and “elaborative rehearsal”. The first type retains information without improving it in any way or explaining it further. This leads to poor encoding. Whereas the second rehearsal assigns meaning to the information to be

remembered therefore leading to good encoding. “Several research programs have accumulated considerable evidence to support the view that more elaborate and distinctive encoding leads to better recall.” (Collins et al. 1994: 251).

Storing information refers to retaining it in short or long-term memory over a period of time and retrieval is the process of finding encoded information in our memory and becoming aware of it, therefore making it accessible for use. Retrieval is therefore the process which enables us to make information available at any given moment. There are three possibilities which would match our current cognitive processes with information that we have previously stored in our memories. The first is that the task of remembering wasn’t successful or that “no entry in memory will match sufficiently for it to be made available” (Collins et al. 1994: 265). The second possibility which can be termed “the act of remembering” is if one piece of information is activated more than other memories, it becomes accessible for use. And the third option refers to the insufficient activation of several pieces of information in our memory, causing the act of remembering to fail.

What could be relevant to the interpretation process is that retrieval in itself is an event which eases certain information to be remembered in future, which means that “after a memory has been activated it is likely that the amount of input necessary to reactivate the memory in the future is lowered.” (Collins et al. 1994: 270). Hence if an interpreter has used a specific term several times and has successfully retrieved it from his or her memory, it is likely that future recall of the same term will be easier to achieve, therefore facilitating the interpretation process.

Encoding, storing and retrieving information are features of memory that are not only used to explain cognition but also need to be understood in connection with interpreting, in order of beginning to understand not only the complexity of the act of interpreting but also to help understand certain techniques which could enable better encoding and hence better retrieval of information. It is suggested that emphasizing questioning while encoding and linking information to preexisting knowledge can enhance the retrieval process. This information could be helpful for interpretation training.

4. Gile’s Effort Model

A different approach towards interpreting was assumed by Daniel Gile in the early 1980s. His model regards short-term memory as a fundamental part in the interpretation process. The main idea in his model was to divide processes which occur during interpreting into different efforts. The Effort Models are designed to help interpreters understand interpreting difficulties and select appropriate strategies and tactics for overcoming them. They are based on the much required concept of Processing Capacity which is needed for the mental operations in interpreting.

What differentiates his model from the models proposed by cognitive psychologists is that he tries to explain errors and omissions which occur during the interpretation process. These features could not be seen as an occurrence of insufficient linguistic abilities, lack of extralinguistic knowledge or poor source text delivery. He therefore divides interpreting in three operational components: the listening and analysis effort (L), the production effort (P) and the short-term memory effort (M). His model assumes that each of these Efforts needs attention and that these components can come to a saturation point of an interpreter, which Gile explains in his *Tightrope hypotheses*.

The Effort Model for consecutive interpreting has “a ‘comprehension phase’, during which the interpreter listens to the source speech and takes notes, and a ‘reformulation phase’, during which the target speech is reconstructed from the notes and from long term memory.” (Baker et al. 2009: 53). It therefore consists of two phases which can be summed up as follows:

Comprehension phase = L (listening) + N (Note-taking) + M (memory effort) + C (coordination)

Production phase = Read (reading) + Rem (remembering) + P (production) + C (coordination)

During consecutive interpretation, depending on the speech segments, the interpreter has up to 15 minutes to encode and store information. This would be considered the first phase of the Effort Model for CI. The second phase is the one in which the interpreter retrieves information and interprets it into the TL.

The Effort Model for simultaneous interpreting can be divided into three phases which include: listening and analysis (L), which is a sum of all the mental operations needed for the interpretation process to take place and in which an interpreter decides on assigning meaning to a segment he/she has just heard; short term memory (M) which is related to the storing of heard

segments and finally production (P) which incorporates the operations needed for an interpreter to articulate an idea or a data. The formula for simultaneous interpreting would hence be as follows:

SI = L (listening and analysis) + M (memory) + P (Production)

During simultaneous interpreting the encoding of information and production of the TL occur at the same time, hence the possibility for storing information is limited. We can come to the conclusion that the role of short-term memory in SI is therefore much greater than in CI.

Although Gile's Effort model takes into account the different components (efforts) in interpreting, his assumption of the saturation level, which could be reached by the interpreter has led to some further theories. Two hypotheses arose, one which claims that due to the saturation level, failure of the interpretation process could happen even if there were slight additional constraints on the interpreter. Another hypothesis having to do with problems arising in redundant speech segments, which could lead towards mismanagement of attention. Gile (1984) noticed that there was a high rate of failure in the rendition of proper names, some that exhibited low morphologic redundancy such as the word *cliff* and some for which more attention is required such as *Pacific Islands Development Commission*.

Gile's Effort Model, proposes that interpreting is an STM-centered activity and it can be summed up as follows:

Encoding of information from the Source Language + Storing Information + Retrieval of Information + Decoding Information into the Target language.

Working memory affect all aspects of simultaneous interpretation, analysis and understanding of discourse in the source language, reformulation from the source to the target language, storing, producing, and language control. The time for storing the information is very restricted. Therefore, the first step of interpreting, encoding of (comprehending) information expressed in the SL is crucial for memory training, which will be discussed in more detail in the following chapters.

5. Cowan's memory model

One of the first models of memory which can be directly linked to the interpretation process was Cowan's model (1988, 1995). He regards a good focus of attention as the main predictor of well-used memory functions of an interpreter.

Cowan has put forward an approach which assumes a hierarchical view of memory. Memory consists of a central executive, the long term store, short term store which he considers to be activated memory and the focus of attention. The main idea is that working memory is an activated part of long-term memory. The hierarchy is developed as follows. The focus of attention is a part of activated memory, which is a part of the LTS. Akira Mizuno (2005: 742) explains Cowan's model by stating that information needed for a task can be in "(a) memory in the focus of attention; (b) memory out of the focus but nevertheless temporarily activated; and (c) inactive elements of memory with pertinent retrieval cues.". Cowan has also added the central executive component to his memory model, however unlike Baddeley's component which serves as a supervisory element, Cowan's controls the focus of attention.

The focus of attention is the main part of his model and as such the most features and research have been assigned to it. The time frame within which the information is accessible for use is 10 to 30 seconds, whereas its capacity is plus or minus 4 items. *Figure 3* illustrates the complexity of his model. Unlike Baddeley and Hitch, whose model serves as a rather structural model and whose components serve merely as stores for information, Cowan focuses on the processes which undergo within each component. His components can be seen as active elements in the cognition process. Mizuno makes a connection between the passive stores (phonological loop and visuospatial sketchpad) of the previously discussed model and Cowan's focus of attention. However Cowan himself attributes the same features of his focus of attention to Baddeley's episodic buffer. Their models can be seen as compatible to a certain degree but in my opinion Cowan's model is more relevant to the interpretation process. The most important feature for interpreting in Baddeley and Hitch's model is the phonological loop which has been explained in the previous chapters. But interpreting is a far more complex skill and Cowan's model where working memory is assumed to be an active part of long-term memory gives rise to the idea that attention as such is the key element in interpreting.

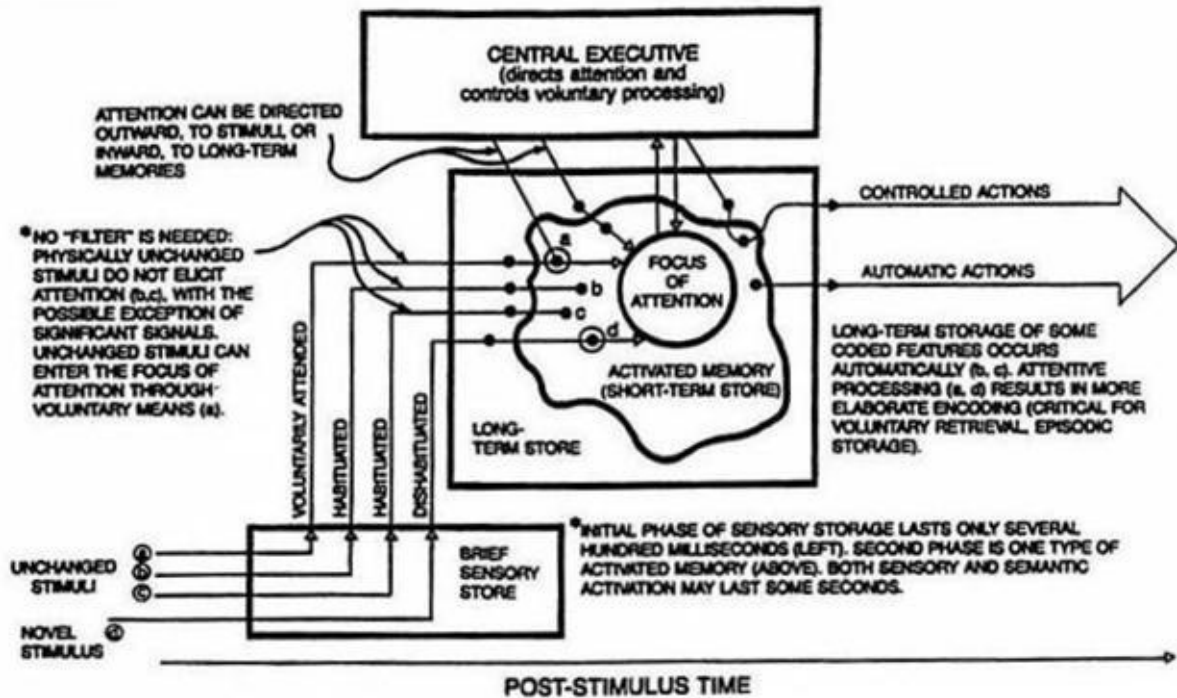

Figure 3 Cowan's model of memory

Let us further explain the effective use of attention on interpreting to bring forward the assumption. Some research has been done in order of linking attention to interpreting. One of them is the study done by Gerver in 1974. He has done a research on experienced interpreters who were listening to French prose passages. Their task was to: a) simply listen to the passage, b) interpret from French to English simultaneously or to c) perform a shadowing task (simply repeating the passage as they were listening to it). The aim of the research was to compare the amount of comprehension that was accomplished during these three tasks. What would be expected is that while performing the simultaneous interpretation task, the attention would be fully shifted towards the task and a small amount of it would be left for comprehension. However the results of the research have given the following data "the percentage of correct responses on comprehension questions was 58% for simple listening, 51% for interpreting, and 43% for shadowing." (Cowan 2000: 123). It can be concluded that although interpreting causes the attention to shift from comprehending and towards the interpretation process, this shift causes a minor reduction in understanding the passage.

Since interpreting and specifically simultaneous interpreting is a recently developed profession there have been rather few studies on its processes as well as the capabilities of the interpreters as such. However two studies have proven the correlation between working memory

and interpreting. While comparing the working memory capacity in trained and novice interpreters, Köpke and Nespoulous (Pöchhacker 2011) have concluded that students of interpreting had a larger working memory than experts, giving rise to the conclusion that experience in interpreting influences the WM capacity. Another study done by Padilla (1995) and by Christoffels (2006) showed that higher working memory capacity was a trait of interpreters when compared to non-interpreters.

If working memory capacity is an important feature for interpreting and Cowan's (2000) memory model assumes working memory, whose subcomponent is the focus of attention; to be an activated part of LTM, his model inextricably links attention to WM. The use of attention in interpreting is undeniable, but the question that we need to answer is, how does an interpreter use this precise focus of attention to convey the message? There are two possible ways that have been suggested so far as to how an interpreter may use his or her attention. One is that an interpreter can swiftly switch attention from listening to the speech towards interpreting it. The other possible explanation is the simultaneous performance of both tasks, which occurs after a certain amount of practice. "This implies that interpreters have a split conceptual attention. One conceptual focus is directed to understanding the input; the other focus is on conceptualizing and producing an earlier part of the message." (Christoffels 2004: 8). If these assumptions could be clarified they would ultimately result in different approaches towards the training of interpreters. A study by Barik (1973) proved that interpreters speak more during the pauses of the input speech, which still means that they speak simultaneously in about 70% of their task. This study shows that there are certain techniques which interpreters use to enhance their output.

Further investigation is needed to understand to what degree interpreters learn to switch their attention between speaking and listening and to what extent they practice in order of making one of their tasks less difficult.

To further explore the effect of attention on the interpretation process it has been suggested that inhibition of certain information or tasks can switch the attention towards the uninhibited part. The control of attention is assumed to be linked to inhibiting information. Good readers are considered those who can do precisely this. To exemplify this hypothesis let us take the word "sweet" which can have a different meaning according to the context. It can mean "pleasing to the taste", „pleasing to the mind or feelings“⁵, etc. A good reader would hence understand the meaning of the sentence "This cake is very sweet" as being "pleasing to the taste" by inhibiting

⁵ *Merriam-Webster Online Dictionary, Web 16 March 2013*

the information that is irrelevant to the meaning of the sentence. The interpreter could accordingly inhibit the unnecessary information and enable the production of the output.

Cowan presented a study which showed that subjects switch attention between processing and storing information, which assumes that instead of sharing attention between concurrent tasks, the successful ones perform the task swiftly. “Thus, strategic attention switching seems important to success in working memory tasks, whereas the involvement of attention sharing perhaps is less clear. “ (Cowan 2000: 132).

If good control of attention has a positive influence on the interpretation process, Cowan suggests that there has to be some feature enhancing attention itself. He assumes that the speed in which information is retrieved from memory can influence interpreting. The retrieval speed refers to the speed necessary for information to enter the focus of attention. Retrieval speed can be measured by different types of working memory tasks. During these tasks a computer is used to measure the time period between the end of a spoken list and the beginning of a spoken recall, the duration of the words in recall, and the duration of pauses. Cowan (2000) has come to the conclusion that pauses between words in the response take longer for list which are longer, within recalled lists. This suggests that what is being processed during recall isn't focused on individual words but rather on lists. Cowan concluded that the pauses didn't depend on word length and weren't in correlation with the speed of rehearsal, but rather depended on the lexical status of verbs. This study is in contradiction with the previously mentioned research done by Ellis and Hennelly 1980)⁶, whereby words that take longer to pronounce, take longer to recall. There are apparently still contradicting opinions about the speed of retrieval and its connection to word length. As Cowan states “the more we learn about retrieval speeds and what processes determine them, the more clues we will have about how to pinpoint the processes contributing to excellent interpreting and to learn how training might be improved.“ (Cowan 2000: 134). If we take into account the different abilities that are needed in order of achieving a good interpretation, we can come to the conclusion that the interpreter needs to possess strong language skills in at least two languages. If the interpreter has a fast spoken fluency, he will have the benefit of performing the interpretation rather quickly; however one could argue that this doesn't specify the quality of his or her delivery. It would be necessary to do further research in order of understanding the connection between the speed of speech and the quality of the interpretation product.

⁶ *Working memory*, Web 7 March 2013

The last point referred to by Cowan was the capacity of the focal point of his model, which is the focus of attention. Though Miller suggested that we could recall 7 chunks of information, Cowan's research suggests that the number of items to be stored in the focus of attention is four. This could be considered important for interpreting in the effect that certain individuals, who could hold more information in their focus of attention, could therefore have a stronger possibility to become a good interpreter. Cowan argued that the ability to form together several items into a greater chunk of information, could allow keeping more information in the immediate memory, hence providing the interpreter with a better cognitive ability.

It is important for further research on this topic to focus on better understanding the capacity limits of interpreters and their retrieval speed in order of knowing which techniques to focus on while learning to interpret as well as who might be naturally better prepared to become an interpreter.

6. Daro and Fabbro's simultaneous interpretation model

6.1 Overview of long-term memory

In order of understanding the model of SI suggested by Valeria Darò and Franco Fabbro, we must first understand some of the complex features of the long-term store. Firstly there is a common understanding that this particular store shouldn't be considered a unified storage but rather a highly complicated multi-storage system.

The first distinction that has to be made is between explicit (declarative) and implicit (procedural) memory. A simple explanation would be that "memories of which we have a conscious awareness are called *explicit* memories, while those that are not so linked to conscious awareness are called *implicit* memories." (Collins et al. 2004: 292). To understand this definition, we can apply it to acquiring a language, which was explained by Paradis (1994). He states that when learning a language, a child instinctively uses the rules that were stored in his implicit memory. Similarly the function of implicit memory is used by adults when they acquire their language competencies over a longer period of time and preferably in an informal way. Any information stored in our memory unconsciously, would be considered implicit memory. However according to Paradis if a language is learned in a formal setting such as a classroom "through the

conscious interiorization and application of grammatical rules, this is thought to require the activation of explicit memory strategies.” (Gambier et al. 1994: 143).

Explicit memory can further be divided into semantic and episodic memory. The former refers to storage of general information and facts. Semantic memory is responsible for the storage of verbal information and is hence important for the interpretation process. Episodic memory “refers to autobiographical recall of one’s own experiences.” (Gambier et al. 1994: 143).

This storage is responsible for the memories we have acquired in the course of our life. Implicit memory refers to a number of different cognitive, motor and perceptual skills. This brief outline of the features of long-term memory will help understand one of the more complex memory models conceptualized by Darò and Fabbro.

6.2 Valeria Darò and Franco Fabbro’s memory model

Unlike the previously discussed models, Darò and Fabbro’s memory model is directly applicable to interpreting because it takes into account the simultaneous interpretation process and uses the terminology assigned to it.

This memory model fractions memory into working memory, a concept they have adopted from Baddeley and Hitch’s model, and long-term memory. The two main components are then further fragmented into subcomponents. Working memory is divided into the central executive component and the verbal subsystems. Since their memory model is a model of simultaneous interpretation, they decided to focus on the verbal subsystems: the phonological store and the subvocal rehearsal. They assume that the source language enters the working memory system and is then furthered into long-term memory (episodic, semantic and procedural). As can be seen from *Figure 4* the center of the model comprises the interpretation direction, either from the native language into the non-native language or vice versa.

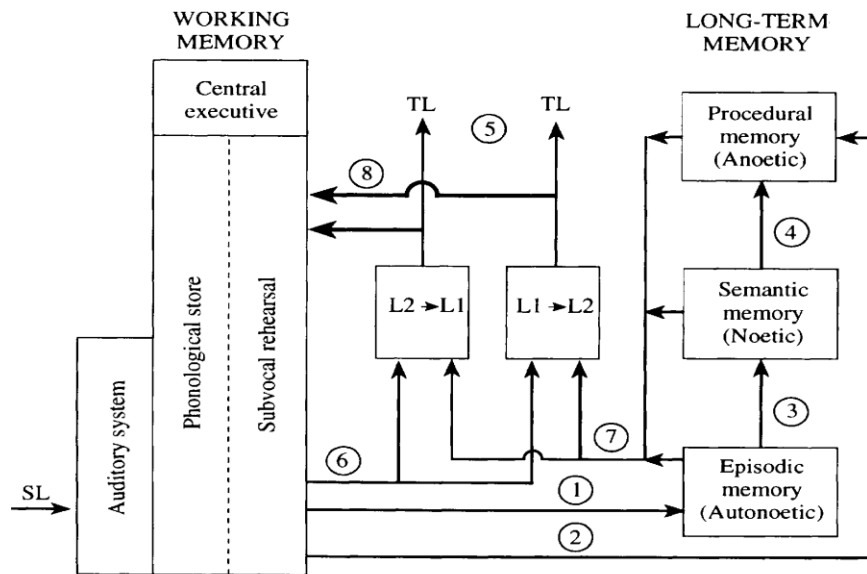

Figure 4 Daro and Fabbro's simultaneous interpretation model

To explain the simultaneous interpretation process in more detail they have conducted several experiments on verbal memory and phonological interference. Their conclusion is that the source-language is processed by the working memory system before it is translated into the target language. Interestingly they assume that verbal chunks of information are held in memory for the duration of 10 seconds and are then either further processed or they simply disappear. Afterwards if the chunks of memory are going to be processed further, they are transferred and stored in long-term memory. "Sometimes, however, a series of chunks is not immediately translated, but processed and coalesced with the contribution of long-term memory systems into a sentence comprised of these chunks." (Hauenschild 1997: 12). The function of long-term memory is to support the neurofunctional systems during the interpretation process.

Some independent studies have shown that after SI the ability to recall what is being heard is intensely impaired. Isham performed a study in 1994 with SI interpreters who worked with English, French and sign-language (Pöchhacker, 2004). His study showed that recall of the last clause of a given paragraph was worse in SI from French into English than SI from English into sign language. This study shows that there might be a form of phonological interference caused by two simultaneous speeches during spoken interpretation.

Daro-Fabbro (1994) came to a similar conclusion in an experimental study where they found that reduced recall during SI is partly due to an articulatory suppression which prevents the functioning of the subvocal rehearsal component with the phonological loop. Twenty-four

beginning interpreters were asked to perform a digit span task and to immediately recall lists of digits in four different states: after listening, shadowing, articulatory suppression and simultaneous interpretation. Compared to the other conditions the subjects' performance in the digit span task was considerably lower after SI. The results prove that interpreting is the most complex task because it disrupts performance on a simultaneous task because of phonological interference. This led to the conclusion that professional interpreters "would develop the ability to resist phonological interference in short-term memory tasks and, in particular, in tasks where cognitive demands are increased through phonological interference." (Köpke, Signorelli 2011: 185).

Listening and speaking simultaneously precludes the phonological loop from functioning properly, hence preventing the functioning of the auditory system of working memory and ultimately affecting the storage of information in long-term memory. This study along with the previously mentioned study done by Gerver (1974) suggests that simultaneous interpreters do not store the information they interpret in LTM but rather that the only memory component which is strengthened is their working memory.

A study done by Lambert (1989) has proven that recall of verbal material was better after consecutive interpreting in comparison to SI. He claimed that during consecutive interpretation the speech was better processed than during SI, which led to reduced storage in long-term memory. Darò and Fabbro however consider a different explanation, namely that during CI there is less interference to the phonological loop than in SI. This assumption could be possible considering that during CI there is no form of articulatory suppression.

The main conclusion that can be drawn from these experiments is that simultaneous interpreters only partly remember the material that they have just interpreted. Barbara Moser Mercer has other possible explanations to account for this feature. Two hypotheses can be postulated to explain the reduction in LTM abilities of interpreters, one which emphasizes the division of attention during SI, which was also taken into account by Cowan, and another which assumes that interpreters have found a way to deal with the huge amounts of information seemingly irrelevant to their lives. The former hypothesis claims that the simultaneous activities during SI interfere with the functioning of both the central executive and working memory. The later takes into account the effect of redundant information on the interpreters.

Spiller-Bosatra, Darò , Fabbro & Bosatra (1990) found that during interpretation different skills are enhanced such as concurrent listening and speaking, divided attention, speaking speed,

however “the practice of interpretation does not simply improve one’s LTM abilities concerning verbal material stored in semantic memory” (Gambier et al. 1994: 145).

If we take into account the formerly discussed features of long-term memory outlined by Paradis concerning the difference between implicit and explicit memory we can correlate those features to the interpretation process. Since SI is considered an implicit strategy or skill, in regards to the automation of this procedure, it cannot be enhanced by the use of explicit strategies, “since practice does not convert explicit knowledge into implicit competence.” (Gambier et al. 1994: 145). Although there haven’t been studies carried out in regards to the continual increase of LTM in simultaneous interpreters, it is sensible to assume that such an occurrence should happen. The studies mentioned in this section have to do with the immediate recall of information, however as storage of information in LTM is a highly complex process, and as mentioned in previous chapters merely repeating information is not enough for it to take place, further research should be done in order of investigating the possibility of the interpreter's LTM enhancing over time.

Let us further explain the function of attention in interpreting as presented by Darò, Fabbro and Lambert. Their study has for the first time taken into account on a rather experimental level to what extent conscious monitoring of attention can influence the quantity and the sort of mistakes made by interpreters in different situations. The results of their study have shown that concentrating on the source speech or on the output did not influence the overall performance of the interpreter.

6.3 Interpreting strategies

In order of achieving a high quality output, interpreters have developed certain strategies that will enable them to do so. These strategies were developed in order of dealing with both time constraints as well as coping with stress. An interpreter during his career is faced with many different speakers. The differences in the speeches that they produce ultimately influence the output of the interpreter. Interpreters may be faced with native or non-native speakers, fast and slow speakers and so on. This chapter will outline some of the strategies that interpreters use to cope with some of these interpreting problems.

6.3.1. Waiting and stalling

Interpreters may experience comprehension difficulties while producing the target language. One of the strategies they can use in this case is to delay their response for a certain amount of time (up to a few seconds). During that time the interpreter revises information with the help of STM while at the same time receiving information from the speaker. The time lag between comprehension and reformulation is the EVS (ear-to-voice span) and by changing it, interpreters can control the processing capacity for efforts.

Waiting is considered to be “the strategy by which interpreters halt production to wait for more input, forces them to store the information they receive in working memory while pausing.” (Kerzel 2012: 3).

It is uncertain if interpreters hold this information in activation through rehearsal until it can be encoded into the target language, or if the information doesn't require subvocal rehearsal due to decaying slowly. Regardless of the answer, this process would be influenced by interference from concurrent language processing tasks. This strategy allows interpreters to temporarily ease cognitive load. By using it, the interpreter interrupts the simultaneity of two tasks, language comprehension and producing the output. Accordingly, interpreting becomes a simpler comprehension and memory task. The negative side is that it causes an increase on the cognitive load of the interpreter.

6.3.2. Chunking or segmentation

Another interpreting strategy is chunking or segmentation. When a source and target language are very different in terms of syntax, if embedded structures are present in the source speech or if the speech itself is unclear, interpreters can apply this strategy in order of reducing the memory load. They can then choose to reformulate speech segments earlier.

Segmenting the speech during interpreting means that the interpreter can use his or her short-term memory to remember the original structure and reorganize the information in the same period of time.

Another interpreting problem can be high-density speeches, known as enumerations. „High speech density is probably the most frequent source of interpretation problems. High speech density is associated with [...] information elements put next to each other without grammatical or other low-density word groups in-between" (Schlesinger, 2003: 3). To deal with this problem

an interpreter may simply reformulate the information in reverse order, which means uttering the last items first in order of freeing their memories and then moving on to former items.

6.3.3. Anticipation

This is a strategy by which an interpreter aims to guess a part of the sentence before it has been uttered in the source speech. The positive side of this strategy is that the interpreter manages to maintain a small lag between his output and the speaker's input. However there is a risk of simply guessing the wrong constituent, which would ultimately lead to reduced quality of the output.

6.3.4. Meaning-based and transcoding strategy

To explain what happens during the process of transmitting the message from SL to TL two interpreting strategies have been proposed: the meaning-based strategy and the transcoding strategy. They are a theoretical approach to interpreting which aims to explain two different ways of rendering the output. They take into account two different ways of seeing the source speech.

The meaning based strategy aims to comprehend the full meaning of the source speech, as would be the case while listening to regular speech and accordingly transmitting it into the target language. "The interpreter is thought to retain the meaning of chunks of information and to recode the meaning of these chunks in the target language." (Christoffels 2004: 13).

The transcoding strategy assumes the translation of the smallest units in the source language that have a meaning in the target language. It "involves the literal transposition of words of multi-word units." (Christoffels 2004: 13). It is questionable as to how useful this strategy really is if it assumes such a simple, one could even argue, a primitive way of translating. However if we take into account the possibility of language levels such as morphology, syntax and semantics, this might be a useful way of rendering the TL. Transcoding therefore involves source text processing at a more superficial level, whereas meaning-based interpreting processes at a deeper semantic level. It is assumed that the usage of both of these strategies takes place during interpreting in order of reaching a high quality output. "It is generally assumed that both techniques are available to trained interpreters, who may alternate between them according to internal or external circumstances." (Dam 2001: 28).

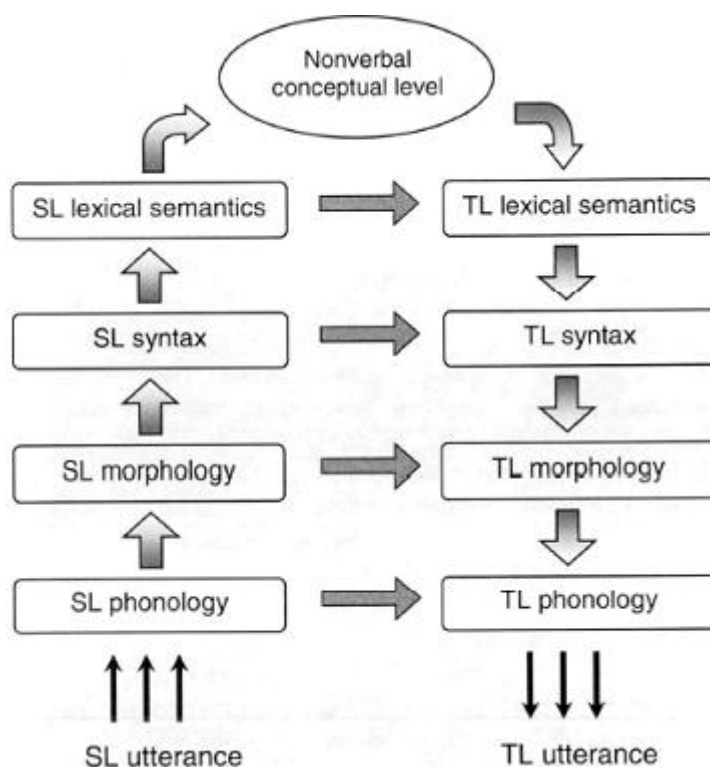

Figure 5 Interpreting strategies based on Paradis. The lighter arrows show the meaning-based strategy and the darker arrows show the transcoding strategy.

6.4 Memory training

This paper has put forward the idea that memory, whether short term or long term is a crucial feature in interpreting. Interpreting, whether simultaneous or consecutive, puts high demands on the cognitive system of the interpreter. In order of producing a high-quality target speech and appropriately conveying the message, the interpreter, apart from the formerly mentioned focus of attention and interpreting strategies needs to have certain means of enhancing his or her memory capacity. Because “formal training in simultaneous interpreting may render individuals more efficient in allocating multiple cognitive resources in real time, one possible outcome could be enhanced working memory span“ (Tzou 2012: 214), memory training for interpreters is indeed important. Having certain memory techniques gives us a quicker access to information stored in our memory. Due to the formation of the human brain, we cannot remember everything that we hear or see especially if it is too complicated or unnecessary for our daily lives. During interpreting

there is very little time to understand the given information, rearrange materials and interpret into the target language. This chapter will outline some strategies used to enable memory enhancement.

The aim of training memory in interpreting is to acquire a better comprehension of the SL. This in turn will enable good interpreting. Comprehension was defined by Pöchhacker as “the act of building a mental representation of language-mediated meaning“ (2002: 131). It is crucial to provide memory training at the beginning of teaching interpreting students. Seeing as the functions of memory are different depending on the interpretation type (consecutive or simultaneous) so are memory trainings. The duration of memory is longer in CI, where the interpreter relies more on his LTM, while he or she uses the short term memory more, specifically working memory on a higher level in SI. During simultaneous interpreting the decoding and encoding of information happens at the same time and hence the storing of information is limited. The key to memory training is therefore to understand the source language speech.

Storing information in the short term memory during interpreting can be achieved in three main ways: acoustic, visual and semantic coding. Interpreters can use visual coding during conferences by means of multimedia or in consecutive with the use of notes.” It is important for the interpreter to not only see all parties to the communication process, but also to have the same visual information they have.“ (Rennert, 2008: 209). However semantic and acoustic coding is mostly used by interpreters and hence the memory training exercises should focus precisely on these.

6.4.1. Retelling a story in the Source Language

The teacher reads or plays a recording of a text that consists of up to two hundred words which the trainees are supposed to retell in the same language and without using notes. In order of remembering as much as possible the students should be encouraged to retell the text using the same wording as the original text.

There are four tactics which should be used by the trainees while they retell the story: categorization, generalization, comparison, description. Categorizing is a tactic by which the trainees put together items that exhibit the same features. During generalization the trainees need to draw general conclusions or a message from examples which are set out in the text. Comparison refers to noticing differences and similarities between certain things, facts and events. The last tactic simply means describing a scene, an object or a shape mentioned in the text. During this

exercise the trainees, by applying the formerly mentioned tactics, train their brains to notice and adequately connect information; hence they achieve a certain comprehension of the text itself, which is important for interpreting. Listening and comprehension are namely more important for interpreting as is stated by Bajo et al. “In fact, it is estimated that an interpreter must devote 80 % of their effort or cognitive ability to listening and comprehension and only 20 % to speech production“ (2001: 2).

The following is an example of a story, which can be used as a comprehensive listening task. After reading the story or playing the recording there are a few questions that could be asked. What was the name of the main character? When did the event happen? What happened?

Yesterday, Tom had an unforgettable experience. While driving to school, he had seen a crowd in the street. He asked a person what they were doing. “Well, Robin Williams is here. Everybody wants to see him and get his signature” “Wow” – Tom thought “He’s my idol. But how to get closer to him? I have an examination this morning”. Leaving with regret, he was so surprised and couldn’t believe his eyes, a stranger in his car, looking at him and smiling “Come on. Help me hide, just a moment”- said Robin. (Duong 2006: 31).

Apart from comprehension, as was stated by Bajo et al. (2001), listening is an important skill for the interpreter. In order of strengthening this particular skill the intensive listening approach is used. The students should listen to specific information and then try to repeat them in a way which is as similar as possible to the original text. This exercise is done in order of establishing a higher short-term memory capacity. In previous chapters of this paper Millers theory of chunks was mentioned, by which we can hold up to seven chunks in our memory. Seeing as our short-term memory is limited by the number of chunks to be remembered, the duration of this particular exercise shouldn’t be too long and the meaning should be simpler. In the example (1) the students should remember the stated list of vegetables.

(1) The following vegetables are rich sources of Omega-3 fatty acids:
pumpkin, sweet peppers, broccoli, carrots, and tomatoes.

In the example (2), the students should try to memorize the number by dividing them into several sets of chunks, for example “897”, “456” and “365”.

(2) 897456365

In the last example (3) the listeners should try to remember the order of the kings.

(3) The kings Narmer, Aha, Djer, Qaa and Den ruled during the 1st dynasty of Egypt.

A more complicated task would be to listen to a longer paragraph. After the teacher reads the paragraph, the students should be able to group the items together, depending on the education level, primary school, secondary school or high school.

(4) I had to learn many subjects at school but I was only good in some of them. At primary school, I was very good in history and geography. The latter was also my favorite subject in secondary school... High school, uhm..., let me try to remember, maths, chemistry and physics – all natural sciences... Well, I forgot, I was also interested in music during junior high school because I am very good in singing.

The last example is a type of game that the students can engage in. One student starts by saying:

Jonny went to the market. Jonny went to the store.

But when poor Jonny got there, he forgot what he went there for.

Momma gave him a list. Momma gave it to him twice.

And what Momma wanted was a big bag of rice.... (Duong, 2006: 33)

The first student mentions the bag of rice and adds another item. Each of the following students has to name all the already mentioned items and add one of their own. As the game progresses the list becomes longer and the recall of the items harder.

6.4.2. Mnemonics

Another tool which is efficient in memory training is mnemonic to memory. Unlike the previous chapter, which focused on acquiring techniques to strengthen STM, mnemonics are a device which enables us to store information more permanently. It is a form of memory aid. In order of storing items in LTM, apart from reading texts which are presented in a rather uninteresting way, there are more creative ways for learning new information. If we want to remember information, which is otherwise difficult to store, we can use the mnemonics methods. An example of mnemonics is the '30 days hath September' rhyme.

30 days hath September, April, June, and November.

All the rest have 31

Except February my dear son.

It has 28 and that is fine

But in Leap Year it has 29.⁷

Mnemonics are used in a way which connects the different functions of our brains in order of achieving more successful information storage. They are used for recalling larger pieces of information, mostly for the storage of lists such as parts, characteristics, phases, etc. The nine basic types of mnemonics are Music, Name, Expression/Word, Model, Ode/Rhyme, Note Organization, Image, Connection, and Spelling Mnemonics. Since the human memory consists of many features and can interpret complex stimuli like images, color, structure, sounds, smells, tastes, touch, spatial awareness, emotion, and language it makes sense to use all of them in order to store information.

While studying students have a tendency to use only the written text as resource. And though reading and writing are certainly one of the most important advances in the human evolution, there are other resources and skills available to our minds. The aim of mnemonics is to use all of these resources. Encoding information in an accurate and reliable manner can be achieved by encoding information into striking images which flow into other strong images.

Another approach which can be used is to perform exercises with interference such as noise. By using this technique we can prevent information loss in the STM, since our surrounding and other information presenting storage may reduce the information encoded. A very effective method to help strengthen the concentration and STM duration of students is to record speeches with specially 'inserted' noises as a background.

Let us exemplify the formerly mentioned types of mnemonics to better comprehend their usage. By using name mnemonics we produce a name of a person or thing from the 1st letter of each word in a list of items. Occasionally, the order of the items can be changed to form a name which is easier to recall.

(5) ROY G. BIV = colors of the spectrum (Red, Orange, Yellow, Green, Blue, Indigo, Violet.)

The most popular type of mnemonics is the expression or word mnemonic. A phrase or word is formed from the first letter of each item.

⁷ <http://www.learningassistance.com/2006/january/mnemonics.html>

(6) Boyles' Law: At constant temperature, pressure is inversely proportional to volume. Boyle's law is best of all because it presses gasses awfully small.

The last mnemonic that will be mentioned and probably also the most interesting one is the image mnemonic. It is an interesting way to acquire knowledge because it is made in the form of a picture that promotes recall of information when you need it. The information is easier to recall if the picture you have drawn is unusual or silly. Image mnemonics can help you remember information regardless of your artistic ability as long as you know what the picture you have drawn means.

7. Cognitive skills and abilities of good interpreters

Throughout this paper we have not only discussed memory and its implications on interpreting, different memory models and techniques for enhancing memory but rather we have introduced the idea that certain attributes are necessary for an interpreter in order of performing his/her job in a high quality. The qualities which will be outlined in this chapter are those which I presume to be the most important to be a professional interpreter.

The question is raised as to what these features or determiners are. What distinguishes a good interpreter from a laic? There are different factors that need to be considered. One could argue that a degree of formal training is necessary for an interpreter to acquire the skills which are needed for this profession. But in order of having access to formal training one has to possess certain skills such as language proficiency. The admission tests for interpreters are designed in a way which “is motivated as much by the belief that a certain aptitude for interpreting is needed in order to become an interpreter, as by practical considerations, such as time and financial constraints.”(Pöchhacker 2011: 32). Apart from formal training and language proficiency, an interpreter must also possess certain personality traits in order of performing this difficult task, as well as methods for coping with stressful situations and cognitive factors such as task switching, mental flexibility, processing speed, etc.

This chapter will outline the most prominent interpreting traits and describe how they are linked to the interpretation process.

7.1. Cognitive abilities

We have discussed cognitive factors in previous chapters where memory, specifically working memory, and attention were mentioned. However it is possible to link other cognitive traits to interpreters. What differentiates highly skilled interpreters from non-interpreters are aptitudes such as processing speed, psychomotor speed, cognitive control, fluid intelligence, task switching and mental flexibility. Let us further explain these features to capture the true essence of interpreting.

Cognitive control is the ability to switch among tasks which are performed by interpreters. There are several tasks, which the interpreter is performing concurrently during SI, such as comprehension of the source message, finding meaning equivalences, planning the output and producing it. To achieve this, the interpreter uses cognitive control.

Another cognitive ability is mental flexibility. Since interpreting is a practice profession such as for example medicine, law or investigation “they require assessments of ever-changing situational and human interaction factors” (Pöchhacker 2011: 125). Interpreters may find themselves in different situations with completely different topics and speakers so they have to adjust their decisions constantly. Mental flexibility is the “capacity to adaptively coordinate actions in relation to others’ actions in interpreting” (Pöchhacker 2011: 125).

Apart from the two features mentioned above, we can conclude that there are certain personality traits such as the motivation to engage in cognitive control and make decisions, reward sensitivity and risk sensitivity. It is important to note that persons with high anxiety might experience certain working memory problems which could ultimately lead towards failure to interpret.

In a study done by Macnamara et al. (Pöchhacker, 2011) highly skilled interpreters were compared with less skilled interpreters to determine aptitudes needed for this demanding profession. They have tested the cognitive abilities mentioned above and came to the conclusion that mental flexibility, task switching ability, psychomotor speed, cognitive processing speed and aversion to risk are important when it comes to differentiating between highly skilled and less skilled interpreters. They suggest that domain-general cognitive abilities might be crucial towards predicting who will become a good interpreter in future. This raises the issue of formal training which will be discussed in the following chapter.

7.2 Formal training

To what degree does formal training influence the abilities of interpreters? The question is whether the traits mentioned are inborn or if they are developed in the course of conference interpreting training. One could argue that if a person possesses strong language skills in their mother tongue and at least another language or if a person is bilingual he or she could be a good interpreter. However interpreting is a skill that needs to be trained just like other professions. We can make an example with teachers. Although a person can have great knowledge of for example geography, he would need other skills such as leadership and the ability to pass on knowledge. Although somebody can possess those skills to a certain degree, it is necessary to train them to become a good teacher. Practice is needed and one could argue that it is crucial in developing the skills of a conference interpreter. There have been several studies which were aimed at discovering to what extent formal training is essential and what differentiates trained from untrained interpreters.

In a study done by Tzou et al. (2011) the influence of duration of formal training on SI performance and working memory was tested in Mandarin–English student interpreters with one year or two years of formal training in interpretation and in 16 Mandarin–English untrained bilinguals. The results showed that SI was much better in Year 2 than in Year 1 student interpreters, and in Year 1 interpreters it was almost equal to bilingual controls. It is interesting to note that the SI performance was also better in advanced L2 users and in high-memory span individuals, whether they had had formal conference interpretation training or not. Both Year 1 and Year 2 students were better at reading span tasks than bilinguals, which suggests that formal training is indeed important. They also concluded that individuals with greater L2 proficiency had higher working memory spans giving rise to the idea that those two features are connected. Their study shows that language processing skills can be enhanced by formal training.

A similar study was done by Liu et al. (2004) in which they compared 11 Mandarin–English professional interpreters with 22 student interpreters. They tested 11 at the end of the first year of training whereas 11 were tested at the end of their second year of training. What is crucial in their study is the fact that the professional interpreters were better at judging and translating essential ideas from the SL. However it is also important to note that both groups exhibited similar working memory span measures. They have “concluded that experts’ superior performance is likely due to greater efficiency in performing domain-specific skills rather than being due to a general enhancement in working memory capacity.” (Tzou et al. 2012: 215).

Another study that should be mentioned is the one done by Christoffels, de Groot, and Kroll in 2006 where they had stated that Dutch–English professionals were better than untrained

bilingual students on a variety of tasks which included word span, reading span (in L2), and speaking span as well as on single word translation in both languages. In another study they found that Dutch interpreters of English had a higher memory span than Dutch teachers of English, although they weren't better in translation which is rather interesting.

These studies prove that formal training is important for interpreting and that untrained bilinguals don't exhibit the needed interpreting skills.

7.3 Coping with stress

Stress is a factor which influences individuals in different ways and strategies to cope with stress are important in a variety of professions. Interpreters are faced with great amounts of stress that are generated with the "real time production" of the output as well as due to other factors such as noise, heat, the inability to see the speakers, multiple tasks, etc.

Blumenthal et al. (2006) listed some stressors, which include the concerns over missing critical information and falsely concluding a threat exists, fatigue, sleep deprivation, physical stress, heavy workload, unexpected assignments, insufficient training or insufficient language proficiency to perform a given task, which were mentioned in the former chapter of this paper and many others.

It is important to note that in psychology, "stress is a complex process by which people perceive and respond to certain conditions that they appraise as threatening." (Blumenthal et al. 2006: 480). This can happen when people are exposed to conditions in which they need to use a high amount of their physical, emotional and cognitive resources. The sources of stress can be internal, which in the case of interpreting could be for example insufficient knowledge of languages, or external, such as noise.

Selye (1951) has described psychological responses to stress which can be chronic. He named these responses General Adaptation Syndrome (GAS). He concludes that there are three phases which our bodies go through when we encounter stressful situations. Those phases are alarm, resistance and exhaustion. The initial response of our bodies to fight against the stressor would be the alarm phase. During this phase our bodies prepare to defend themselves against the stressor. In the second phase, the resistance phase, the body tries to compensate and to adapt. Exhaustion occurs when we are repeatedly exposed to stress for a long period of time, which of

course means that the last phase isn't always reached but rather it occurs when we are exposed to chronic stress. However, should the person in question come to the last stage of stress he or she will have a weakened immune system which means that the body is susceptible to disease and possibly even death if the stress is extreme. This shows that stress as such is something highly dangerous and in order of living and possibly even surviving a stressful job one has to develop strategies in order of coping with stress.

There are many more stressors which can occur at a job such as cognitive responses. In the context of interpretation they are of course highly important and should be taken into account. Those include lack of awareness, reduced vigilance, inability to concentrate, and so on. These can influence the way in which a person perceives him or herself and also the efficiency of their task performance.

Emotional stressors are another factor that should be considered. They include frustration, agitation, depression and anger which can weaken performance by competing for resources. Sometimes stress can even become the focus of attention. "It is also important to note that the physiological, cognitive, and emotional effects are by no means independent; rather they influence each other, potentially exerting additive or multiplicative effects on performance." (Blumenthal et al. 2006:481).

All of these can influence the interpreter negatively, both psychologically and physiologically, and there are recommendations in order to help fight against these stressors. What helps interpreters is if they receive the material about the topic before, limiting working hours, taking enough breaks (changing every 30 minutes), as well as booth size, temperature, and so on.

8. Conclusion

After exploring memory, its functions and the cognitive models that attempt to explain not only memory but also its implications on the interpretation process, we can come to the conclusion that there are many different factors which influence interpreters. Interpreting is a highly complex task and many attributes are needed in order to produce a high quality output. Memory, working memory in simultaneous interpreting, long term memory in consecutive interpreting and the focus of attention can be regarded as the most important cognitive skills and abilities of good interpreters. Although factors such as formal training, coping with stress and developing interpreting strategies are important for the interpretation process, in my opinion, which is based on the experience that I have in simultaneous and consecutive interpretation training, the most important factors are fluency in the required foreign languages, working memory and the focus of attention. During the interpreting training which I have received I regarded the focus of attention as the most crucial factor. While interpreting in the booth regardless of other factors such as stress, if one is able to truly focus on the task, in that precise moment nothing exists apart from you as an interpreter and the speaker. I consider good

interpreters those who can achieve a high focus of attention, which will ultimately exclude everything that is irrelevant to the interpreting task and include all of the factors that are relevant.

References:

Bajo, Teresa, Padilla, Ricardo Presentación, Muñoz, Francisca, Padilla, , Carlos Gómez, Carmen M^a Puerta, Pilar Gonzalvo, Pedro Macizo, (2001). Comprehension and memory processes in translation and interpreting.

Baker, Mona, Gabriela, Saldanha (2009). *Routledge Encyclopedia of Translation Studies*. Taylor & Francis e-Library.

Blumenthal, Pamela, Britt, Thomas W., Cohen, Jason A.; McCubbin, James, Maxfield, Nathan; Michael, Erica B., Moore, Philip, Obler, Loraine K., Scheck, Petra; Signorelli, Teresa M., Wallsten, Thomas S. (2006). Stress effects on bilingual language professionals' performance. *International Journal of Bilingualism* 2006 10: 477.

Christoffels, Ingrid .K. (2004). Simultaneous Interpreting: A cognitive perspective. *Cognitive studies in simultaneous interpreting*.

Collins, Alan F., Philip, Levy, Peter E., Morris, Mary M., Smyth (1994). *Cognition in Action*. East Sussex (United Kingdom): Lawrence Erlbaum Associates Ltd.

Cowan, Nelson. (2000). Processing limits of selective attention and working memory: Potential implications for interpreting. *Interpreting* 5:117-146.

Dam, H.V. (2001). On the option between form-based and meaning-based interpreting: the effect of source-text difficulty on lexical target text form in simultaneous interpreting. *Interpreter's Newsletter* 11, 27-55.

Daró, Valeria (1997). Experimental Studies on Memory in Conference Interpretation. *Translators' Journal* 622-628.

Daro, Valeria, Franco, Fabbro, Sylvie, Lambert (1996). Conscious monitoring of attention during simultaneous interpretation. *Interpreting* 24:101-124.

Duong Thuy, Tran (2006). How to improve short- term memory in interpreting. *Ministry of education and training, Hanoi University of Foreign Studies*.

Gambier, Yves, Daniel, Gile, Christopher, Taylor (1994). *Conference Interpreting: Current Trends in Research: Proceedings of the International Conference on Interpreting - What Do We Know and How?* Amsterdam: Benjamins.

Hauenschild, Christa, Susanne, Heizmann (1997). *Machine Translation and Translation Theory*. Berlin/New York: Mouton de Gruyter.

Köpke, Barbara, Teresa M., Signorelli, (2011). Methodological aspects of working memory assessment in simultaneous interpreters. *International Journal of Bilingualism*. 16: 183.

Lambert, Sylvie (1988). Information Processing among Conference Interpreters: A Test of the Depth-of-Processing Hypothesis. *Translators' Journal*. 33: 377-387.

McLeod, S. A. (2008). Working Memory. *Peterson and Peterson 1959 - Simply psychology*. Retrieved from <http://www.simplypsychology.org/peterson-peterson.html>

Mizuno, Akira (2005). Process Model for Simultaneous Interpreting and Working Memory. *Translators' Journal* 739-752.

Nolan, James (2005). *Interpretation Techniques and Exercises*. Clevedon, Buffalo, Toronto: Multilingual Matters Limited.

Pöchhacker Franz, Miriam Shlesinger. (2002). *The interpreting studies reader*. London/New York: Routledge.

Pöchhacker, Franz, Miriam, Shlesinger (2011). *Aptitude for Interpreting*. Vienna: John Benjamins Publishing Company.

Pöchhacker, Franz. (2004). *Introducing Interpreting Studies*. London: Routledge

Posner, Michael (1998). *Foundations of cognitive science*. Cambridge, Mass.: MIT..

Rennert, Sylvi (2008). Visual Input in Simultaneous Interpreting. *Meta: Translators' Journal*.

Schlesinger, Miriam (2003). Effects of presentation rate on working memory in simultaneous interpreting. *The Interpreters' Newsletter* 12: 37-49.

Seeber, Kilian G. (2011). Cognitive load in simultaneous interpreting. *Interpreting* 176–204

Timaraova, Šárka (2009). Working Memory and Simultaneous Interpreting. *Paper presented at Translation Studies: Moving In - Moving On, Joensuu, Finland, 10-12 December 2009*.

Yeh-Zu Tzou, Zohreh R. Eslami, Hsin-Chin Chen and Jyotsna Vaid (2012). Effect of language proficiency and degree of formal training in simultaneous interpreting on working memory and

interpreting performance: evidence from Mandarin–English speakers. *International Journal of Bilingualism*.

Internet sources:

Merriam-Webster Online Dictionary- Web 7 March 2013

<http://www.merriam-webster.com/dictionary/memory>

Working memory- Web 7 March 2013- Article

<http://www-psych.stanford.edu/~ashas/Cognition%20Textbook/chapter6.pdf>

Online Etymology Dictionary- Web 10 March 2013

http://www.etymonline.com/index.php?term=interpret&allowed_in_frame=0

The learning center exchange- Web 3 May 2013

<http://www.learningassistance.com/2006/january/mnemonics.html>