

# (De)Construction of Gender in the Novels of Louise Erdrich

---

KameniĆ, Nina

Master's thesis / Diplomski rad

2014

Degree Grantor / Ustanova koja je dodijelila akademski / stručni stupanj: **Josip Juraj Strossmayer University of Osijek, Faculty of Humanities and Social Sciences / Sveučilište Josipa Jurja Strossmayera u Osijeku, Filozofski fakultet**

Permanent link / Trajna poveznica: <https://urn.nsk.hr/urn:nbn:hr:142:440354>

Rights / Prava: [In copyright](#) / [Zaštićeno autorskim pravom.](#)

Download date / Datum preuzimanja: **2024-08-08**



Repository / Repozitorij:

[FFOS-repository - Repository of the Faculty of Humanities and Social Sciences Osijek](#)



Sveučilište J.J. Strossmayera u Osijeku  
Filozofski fakultet

Diplomski studij engleskog jezika i književnosti i hrvatskog jezika i književnosti  
– nastavnički smjer

Nina Kamenić

**(De)Construction of Gender in the Novels of Louise Erdrich**

Mentor: izv. prof. dr. sc. Sanja Runtić

Osijek, 2014.

## **Acknowledgement**

A large part of this paper was completed during my stay at Masaryk University in Brno, Czech Republic within the Erasmus exchange program in the 2013-14 academic year. Hereby I thank Professor Mgr. Pavla Buchtová whose valuable advice and guidance contributed greatly to the initial research and my better understanding of contemporary Native American literature, and inspired me to choose this topic.

## Table of Contents

<b>Abstract</b> .....	2
<b>Introduction</b> .....	3
1. <b>The Life and Work of Louise Erdrich</b> .....	5
2. <b>The Novels – Background Information</b> .....	8
2.1. <i>Love Medicine</i> .....	9
2.2. <i>Tracks</i> .....	3
3. <b>(De)Construction of Gender</b> .....	16
3.1. <b>The <i>Berdache</i> Concept</b> .....	17
3.2. <b>The <i>Trickster</i> as a Character</b> .....	19
3.3. <b>Louise Erdrich's Narrative Tricksterism</b> .....	22
3.4. <b>Louise Erdrich's Female Characters as <i>Tricksters</i></b> .....	25
3.4.1. <b>Physical Appearance</b> .....	27
3.4.2. <b>Character, Personality, and Social Status</b> .....	33
3.4.3. <b>The Mother Figure and Fluid Identity</b> .....	43
3.4.4. <b>The Tale of Two <i>Trickster</i> Sisters</b> .....	47
<b>Conclusion</b> .....	50
<b>Works Cited</b> .....	54

## Abstract

Louise Erdrich is an important contemporary Native American writer of mixed heritage, known for her peculiar narrative style that employs intratextuality and the use of multiple narrators, presenting the readers with narrative crossovers and the possibility to perceive her fictional world from a variety of perspectives. One of the prominent themes that Erdrich explores in her novels is the perception of femininity and fluid gender identity. Her novels *Love Medicine* (1984) and *Tracks* (1988) introduce certain female characters whose looks and personalities can be compared to those of traditional Native American archetypes – the *berdache* and the *trickster* – the figures with no fixed identity that combine elements of various cultures, worlds, and even genders, and live in marginal and liminal spaces.

This paper discusses the concept of the *trickster* in *Love Medicine* and *Tracks* as a tool for deconstructing the stereotypes about Native American women and the Western concept of gender roles and gender identity, observable both as an element of characterization and as a narrative strategy. It focuses on the characters of Fleur Pillager, June Morrissey, Lulu Nanapush, and Marie Kashpaw, whose identity is liminal and fluid as they incorporate both the feminine and the masculine traits. In order to uncover these characters' *berdache/trickster* nature, the analysis pays special attention to their physical appearance, personality, character, social status, relationship with other characters, as well as their ability to transcend both the physical and the narrative boundaries. Finally, it defines Louise Erdrich's unique technique of narrative fragmentation and playfulness as an important indicator of the *trickster* discourse.

**Keywords:** Louise Erdrich, (de)construction of gender, *berdache*, *trickster*, *Love Medicine*, *Tracks*

## Introduction

Louise Erdrich is one of the best known and most important contemporary Native American writers. Her fiction has won many awards and has been attracting many avid readers, both among scholars and laypeople. Her narrative technique and use of multiple narrators is skillful and complex, even tangled and chaotic; yet, those readers who manage to follow through the plotline and who get to know her charismatic characters regularly fall in love with her fiction.

Erdrich, who is of mixed heritage herself, offers writings positioned in between two cultures, Native American and the Catholic one, thus enabling the reader to interpret the events and stories from different angles. Among other themes exploited in her many novels, Erdrich also brings into focus the concept of a fluid identity, as well as a different interpretation of femininity and gender identity. Moreover, she resists typical images of Native American women constructed by popular Western culture. She does so by drawing on traditional *trickster* narratives and creating strong female *trickster* and *berdache* characters, which incorporate both feminine and masculine characteristics in their intriguing personalities.

This paper explores the idea of (de)construction of gender through *tricksterism* in two of Erdrich's novels from the North Dakota series: *Love Medicine* (1984) and *Tracks* (1988). The first two chapters of the paper provide the information about the author's background, life, and work, as well as the basic information about the setting, style, themes, and motifs of the analyzed novels. The third and most important chapter draws on the work of critics of Native American literature such as Barbara Babcock, Franchot Ballinger, Julie Barak, Jay Cox, Caroline Rosenthal, Karla Sanders, Jeanne Smith, and Gerald Vizenor and the anthropologist Paul Radin to explain the concepts such as *berdache*, *trickster*, *narrative*

*tricksterism, transgenderation, marginality, and liminality.* Finally, examples of several major female characters from these novels are used and explored in detail in order to demonstrate how Erdrich incorporates these concepts into her writing and how the *trickster*-like nature of her characters enables her to deconstruct the existing stereotypes about Native women and gender in general.

## **1. The Life and Work of Louise Erdrich**

Louise Erdrich is an American writer of novels, poetry, and children's books featuring Native American settings and characters. She is an enrolled member of the Turtle Mountain Band of Chippewa Indians, also known as Anishinaabe, Ojibwa and Chippewa.

She was born in 1954, in Little Falls, Minnesota and grew up in a small town Wahpeton in North Dakota's Red River Valley. She was born to Ralph Louis Erdrich, a German-American, and his wife Rita Joanne, half French-American and half Ojibwe, who were both teachers in a boarding school run by the Bureau of Indian Affairs. Growing up in a big family with six siblings, Erdrich experienced a "strong sense of connection to community that emerges as a theme in each of her novels" (Stookey 1), and has remained close to her family throughout her life. Her Ojibwa and French grandparents on her mother's side of the family lived on North Dakota's Turtle Mountain Reservation, and the upbringing in these circumstances obviously influenced her work. Erdrich was raised a Catholic; thus her work also reflects Catholic tradition, showing many Native American characters living within two religious traditions, just as her grandfather Patrick Gourneau observed both Catholicism and his traditional Chippewa religion (Stookey 9).

She went to Dartmouth College, where she was among the first group of women admitted to the college, and in the same year Dartmouth introduced a new program in Native American Studies. There she met her future husband Michael Dorris, an anthropologist from Yale, who was hired to head the college's new Native American Studies Program (Stookey 3). During her college years, Erdrich majored in English and Creative Writing, but she also took some courses in Native American Studies and started to be more interested in her own Ojibwa background. She moved to Boston after graduate school, and there she worked within an urban Indian community. That experience was different from her previous experience of



Native American life in reservation communities: “She encountered many people who were, like her, of mixed blood, and she realized that her own Native tradition was an important part of her life and something that she wanted to write about;” she realized that she “didn’t choose the material; it chose [her]” (Stookey 4).

Erdrich renewed her connection with Michael Dorris in 1979. Eventually, they got married and Erdrich became adoptive mother to three Native American children whom Dorris had adopted earlier as a single man. They also had three daughters together. Their marriage later became a “literary partnership” as they worked in collaboration, beginning with writing romance fiction under a genderless pseudonym Milou North, combined out of their names. In 1996 Erdrich and Dorris separated after fifteen years of marriage, and Dorris committed suicide the following year (Stookey 4).

Erdrich started her writing career with poetry, which is evident in her lyrical prose, use of metaphors and reoccurring motifs, but in the 1980s she began moving from poetry to fiction. She was writing short stories that were interconnected, and she eventually linked them together in *Love Medicine* and her later novels. Independent stories became correlated and turned into a larger design of not just a single novel, but of as much as five of her North Dakota novels that are interconnected with one another. Tales that were told in one of the novels were retold in others, in different contexts and from different perspectives, and so a new pattern of a story within a story began to emerge. Only *The Crown of Columbus*, which Erdrich wrote in collaboration with Dorris, diverges from the typical intratextual design of her work.

The critics often compare her complex series of interrelated novels with William Faulkner's Yoknapatawpha novels, because both writers create multiple narratives in the same fictional setting. Many critics also describe Erdrich’s work as “literature of ‘homing’, which is

to say that it is fiction wherein a sense of home and place plays a central role” (Stookey 8). Almost all of her novels, except *The Crown of Columbus*, are set in the Midwestern plains states, places where she grew up because her affection and attraction to North Dakota and Minnesota remained in her blood. The theme of homing in is one of the central themes throughout Erdrich’s work; it is expressed over and over again in the quests of her characters to find or to return to the place where they belong, a place they call home (Stookey 9). Her novels display the idea that “home is the site of identity and connection,” and although not always a joyful occasion, it is a way for the characters to come to terms with who they are and where they belong (Stookey 25).

After her first novel, *Love Medicine*, Erdrich published *The Beet Queen* (1986), still using the technique of multiple narrators, but expanding the fictional reservation universe of the previous novel to the nearby town of Argus, North Dakota. Next was *Tracks* (1988), the novel which is most rooted in Anishinaabe culture. *The Bingo Palace* (1994) provides more information about some characters' conflicts from *Love Medicine*. *Tales of Burning Love* (1997) continues and finishes the story of Sister Leopolda, a character appearing in all the previous novels, and brings some new white people into Erdrich’s fictional universe. The first novel set outside the continuity of the previous books is *The Antelope Wife* (1998). Later she returned again to the her fictional world of the reservation and nearby towns, publishing five novels since 1998 dealing with events in that setting, among which are *The Last Report on the Miracles at Little No Horse* (2001) and *The Master Butchers Singing Club* (2003). In 2009, her novel *The Plague of Doves* was named a finalist for the Pulitzer Prize in Fiction. Erdrich now lives in Minneapolis, with her three young daughters. She continues to write, studies the piano and takes lessons in Ojibwa. In 1996 she published her first children’s book, *Grandmother’s Pigeon*, and has continued writing children’s literature alongside her regular novelist writing (Stookey 7).

## 2. The Novels – Background Information

Out of many novels written by Louise Erdrich, this paper deals with two of them: *Love Medicine* and *Tracks*. Before analyzing how Erdrich deconstructs ideas about gender within these novels, it is useful to provide a minimum of background information about the novels' setting, style, themes, and motifs.

Both of these novels are primarily set in North Dakota. In their *Reader's Guide to the Novels of Louise Erdrich*, Beidler and Barton provide a map that shows the outline of that state and indicates the settings of the first five North Dakota novels (cf. fig. 1).

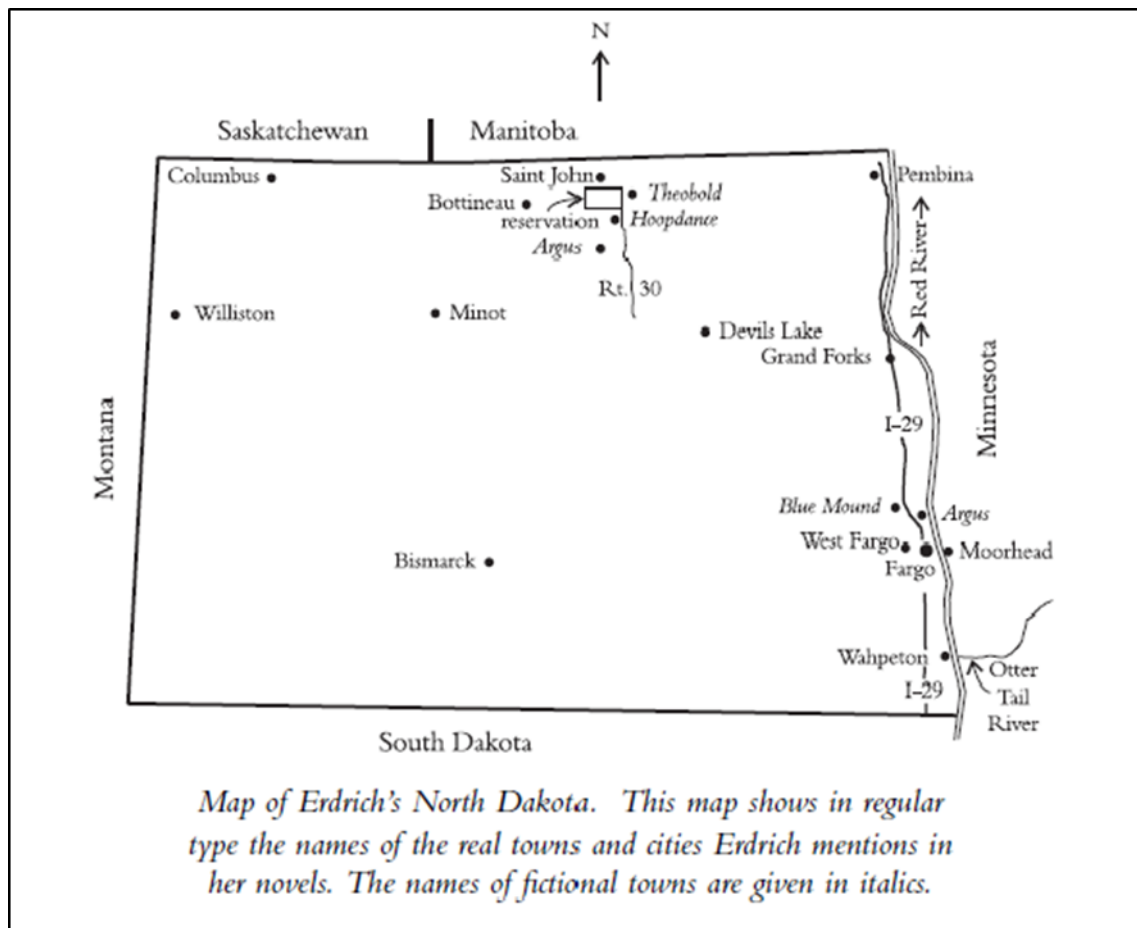

Fig. 1. Map of North Dakota in Erdrich's novels (Beidler and Barton 8)

The fictional reservation, which is central in the novels, is never named, but it can be assumed that it is modeled on Erdrich's own Turtle Mountain Indian Reservation. Near the reservation there are two fictional towns mentioned, Argus and Hoopdance, but Erdrich does not reveal their exact location.

In her novels, Erdrich introduces large sets of characters whose lives and stories are intertwined so that sometimes it is hard to follow the complex relationships of those characters. Therefore, it would be difficult to create a single genealogical chart that would show all of the families and relations between their members. Beidler and Barton have provided several genealogical charts of different families, generally based on each novel separately with the information relevant for that particular novel. Those charts will be provided separately in this paper as well. In all genealogical charts double lines between two boxes (===) indicate either Indian or Western-style marriage; broken double lines (= = =) indicate non-marital sexual liaisons; single lines ( - - ) indicate children resulting from these unions.

## **2.1. *Love Medicine***

*Love Medicine* is Louise Erdrich's first novel, published in 1984. It was revised and expanded for an edition issued in 1993 (Beidler and Barton 14), and then revised again for the 2009 edition. This paper, however, uses the version of the novel as it was first published. The novel spans sixty years through various stories told by different narrators, which create a narrative about several interconnected families that live on Erdrich's fictional Indian reservation in North Dakota.

*Love Medicine* and the other texts do not have a form of "traditional, linear, protagonist-oriented narratives," but are rather written "at the 'edge' of the genre of the novel, drawing narrative strategies from the oral traditions of her [Erdrich's] Native American heritage to

fabricate unconventional designs for her storytelling" (Stookey 31). Some chapters from Erdrich's novels have been published separately as short stories, and some theorists have suggested that the novels can be described as a "short story sequence," or the "short story cycle" (Stookey 32). According to Stookey, a story cycle can be defined as "a set of stories linked to each other in such a way as to maintain a balance between the individuality of each of the stories and the necessities of the larger unit" (32). Luscher has proposed that the term "short story cycle" be replaced with the "short story sequence," explaining that

the story sequence repeats and progressively develops themes and motifs over the course of the work; its unity derives from a perception of both the successive ordering and recurrent patterns, which together provide the continuity of the reading experience. (qtd. in Stookey 33)

Kenedy suggests that Erdrich is writing "at the edge of the novel" (qtd. in Stookey 33). Erdrich herself explains that her technique "'reflects a traditional Chippewa motif in storytelling' wherein an account of one incident 'leads to another incident that leads to another'" (33).

The author has provided dates for all of the chapters, and, after the first one, they are all presented in a chronological order. Most chapters are narrated by six characters, presenting the voices of multiple narrators, while others are told from a third-person perspective that emphasizes a particular character's point of view. According to Ingram, this results in a feeling that the stories are linked to each other in ways "that invite the reader to experience them as parts of a larger whole" (qtd. in Stookey 32).

The relationships between the novels' three major families – the Kashpaws, the Lazarres, and Lulu Nanapush's extended family – are complex. One of the important characters is also June Morrissey, even though she freezes to death in the very first chapter of the book. Nevertheless, she is related in important ways to all three families and parts of her

story are told from different perspectives by different narrators. One of the central conflicts in the novel revolves around Nector Kashpaw's relationship with his wife, Marie Lazarre Kashpaw, and his old flame and lover Lulu Nanapush. He and Marie together have five children, but one of Lulu's sons is also Nector's. Several subplots intertwine in the novel, told by various character-narrators, who are all a part of the bigger story. These include Gerry Nanapush's relationship with June, and later with Dot Adare; Gordie Kashpaw's grieving because of June's death; Beverly Lamartine's love for Lulu that leads to the birth of Henry Junior; Albertine Johnson's adjusting to her family after June's death; Lyman Lamartine's efforts as an entrepreneur; and Lipsha Morrissey's efforts to give love medicine to Nector and to discover who his parents are.

Beidler and Barton provide three charts, useful for a better understanding of the characters and their interrelated families, including some characters who are important for our analysis – June Morrissey, Lulu Nanapush, and Marie Kashpaw (cf. fig. 2, 3, and 4).

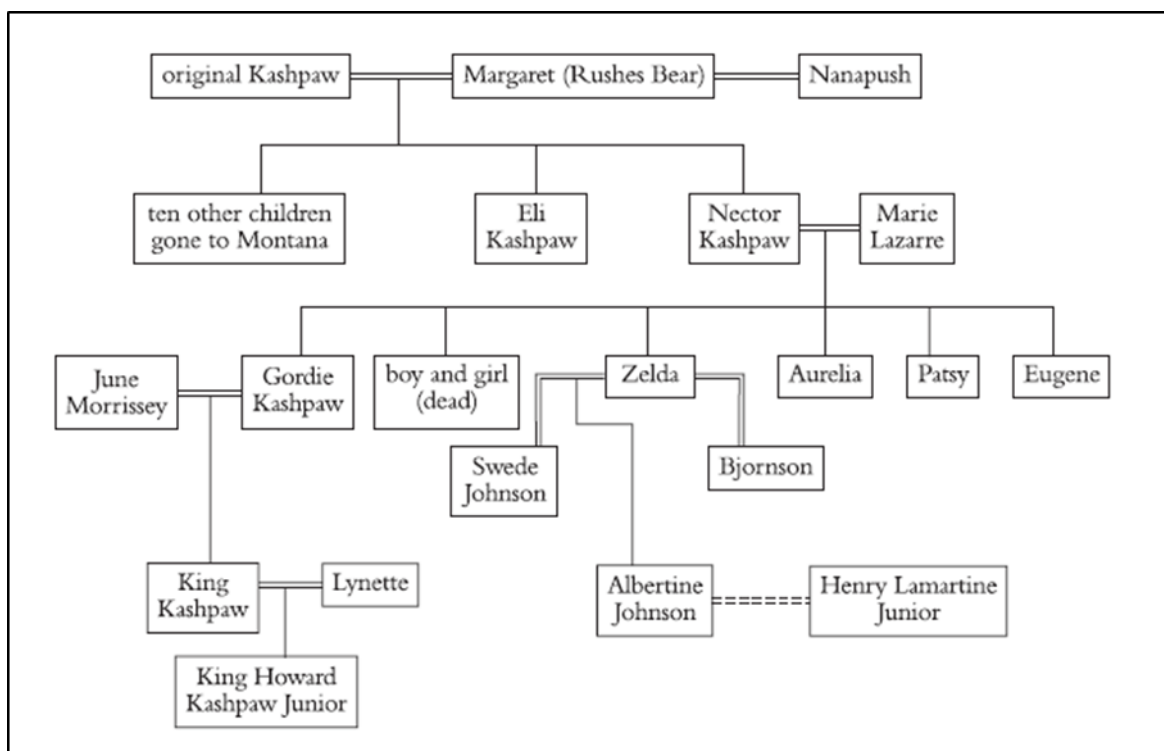

Fig. 2. Kashpaw family in *Love Medicine* (Beidler and Barton 16-17)

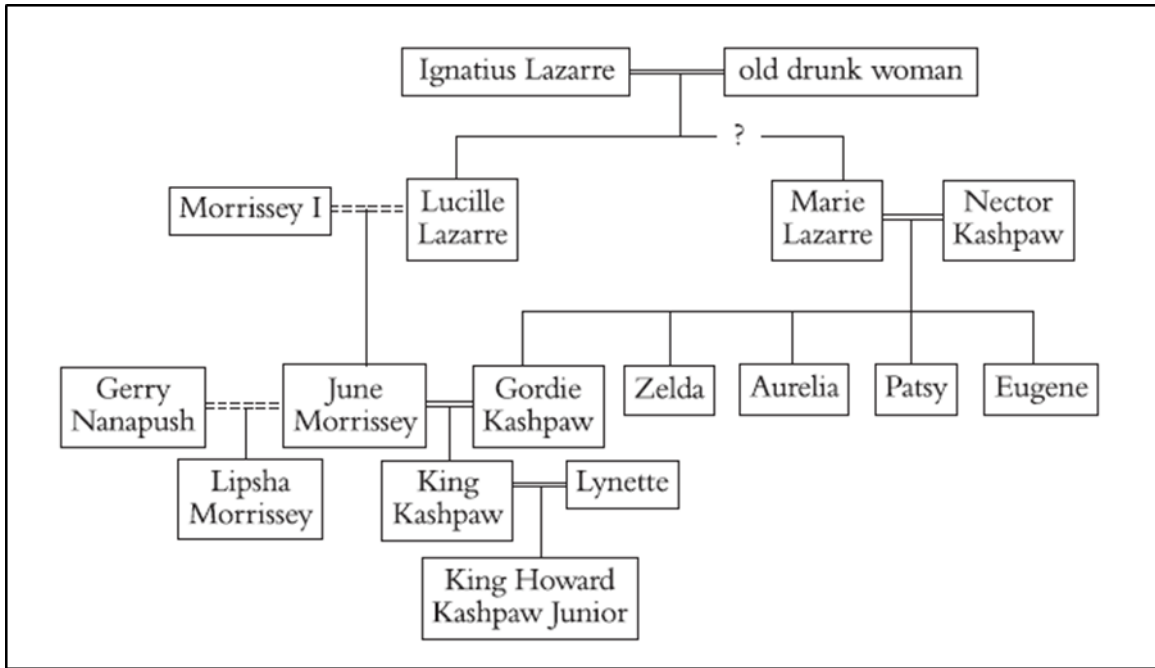

Fig. 3. Lazarre family in *Love Medicine* (Beidler and Barton 16-17)

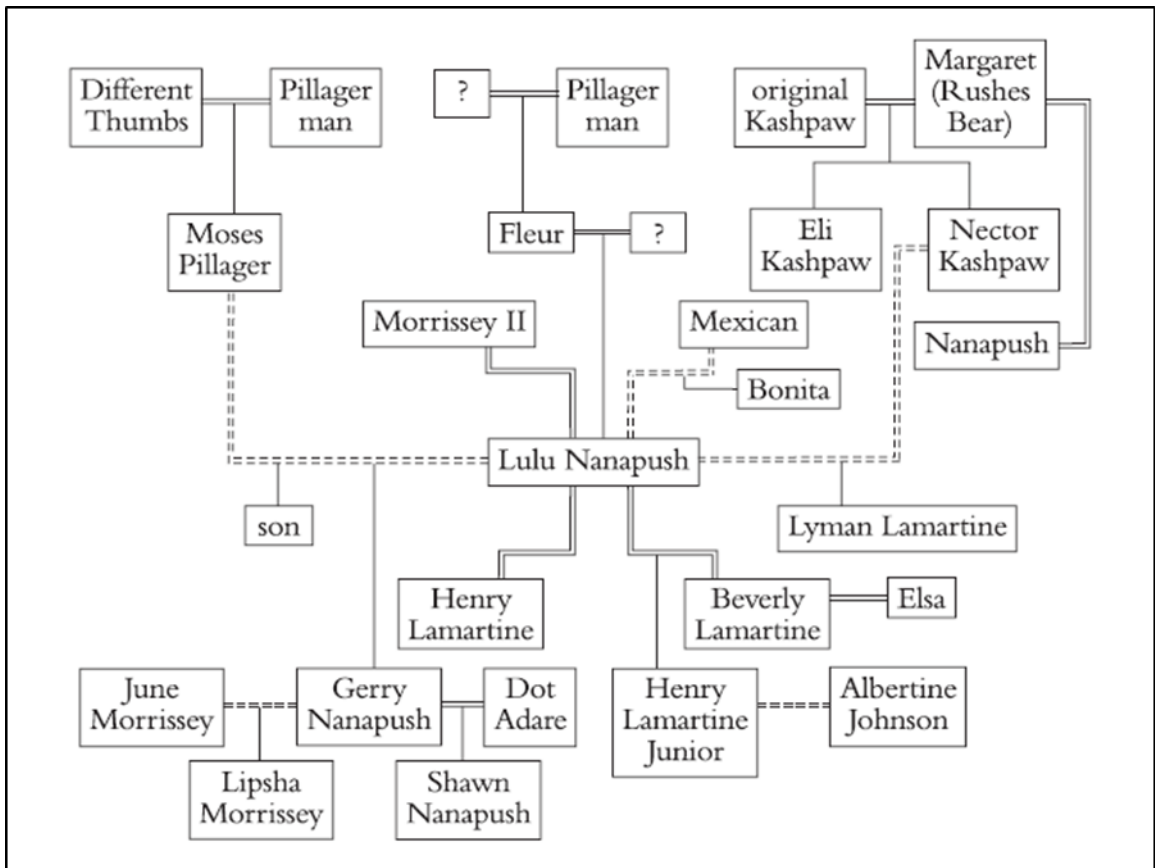

Fig. 4. Lulu's extended family in *Love Medicine* (Beidler and Barton 16-17)

## 2.2. *Tracks*

*Tracks* was published in 1988. It is the third in a series of novels beginning with *Love Medicine* that explores the intertwined lives of families living on Erdrich's fictional Indian reservation. Chronologically, *Tracks* is the earliest among the novels, set in the twelve-year period from 1912 to 1924, and provides the background story of some characters, such as Lulu Nanapush and Marie Kashpaw, the early activities of Nector in politics, Sister Leopolda's early life under the name Pauline, and the loss of a large portion of the reservation land to the lumber companies. *Tracks* is set during the historical period following the implementation of the 1887 Dawes Allotment Act that made possible the allotment of parts of land that had been communal reservation property to individual tribal members (Stookey 72).

Just like in *Love Medicine*, the author uses multiple first-person narratives to connect the events of the plot. This time, however, there are only two narrators – Nanapush, a tribal patriarch, and Pauline Puyat, a young girl troubled by her mixed white-Indian heritage. Nanapush is a more reliable narrator, whose motives are to convince young Lulu that she should not hate her mother, Fleur Pillager, for abandoning her. Pauline is not so reliable and she seems to want to justify her own fanatical actions. She is envious of Fleur and eager to distort the truth, not just to reveal it. Both Nanapush and Pauline focus on Fleur, a young remarkable medicine woman with an inexplicable ability to survive death herself while bringing deaths upon the others. After the consumption takes the lives of many people at the reservation, Nanapush rescues the nearly dead Fleur, whose family was also wiped out. The relationship between Nanapush and the Pillager family is in name rather than blood, and Nanapush names Fleur's daughter Lulu Nanapush after himself, although he is not the father. He also chooses her first name, which is the same as the nickname of his own daughter, Lulu, who died during the consumption as well. As a grown woman, Fleur's daughter Lulu is one of the central characters in *Love Medicine*.



Beidler and Barton depict the relationships within some of the families relevant in *Tracks* through the following charts, which are also relevant for the character analysis of Fleur Pillager and Marie Kashpaw in this paper.

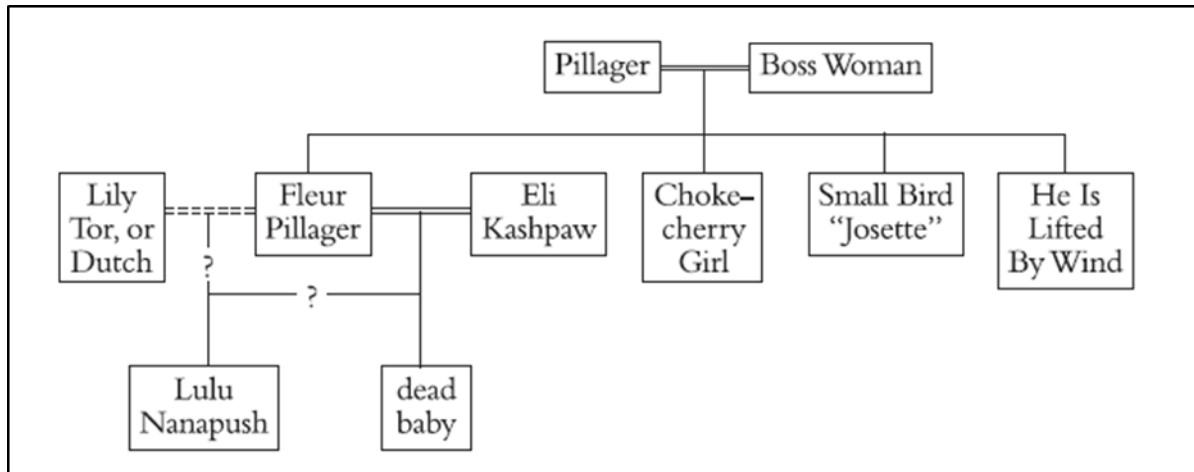

Fig. 5. Fleur's family in *Tracks* (Beidler and Barton 24-25).

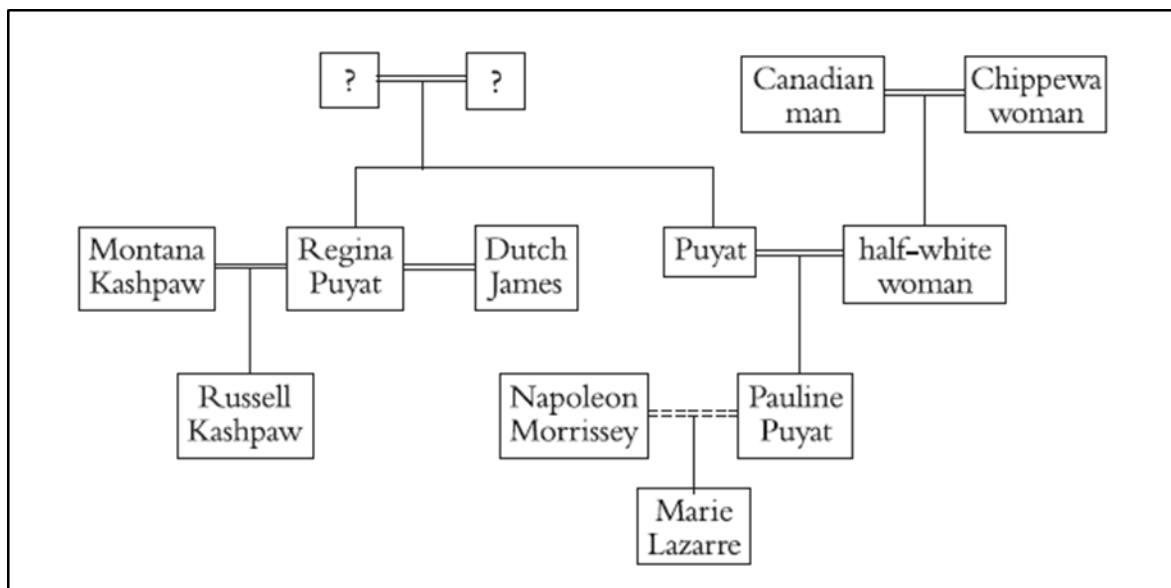

Fig. 6. Puyat family in *Tracks* (Beidler and Barton 24-25).

According to Stookey, *Tracks* is considered to be Erdrich's most overtly political novel, because she "directly portrays the historical circumstances of which these characters are survivors and thus invokes images of cultural catastrophe" (70). While in *Love Medicine* we

see characters who are dedicated to protecting the remnants of their culture, the characters in *Tracks* have lived closer to that culture and must survive the experience of a people's loss.

### 3. (De)construction of Gender

During the last several decades, the concept of gender has received increasing attention across different disciplines. According to Rosenthal, "theories of subjectivity have illustrated that identity is not something we achieve and possess but something individuals must consistently reestablish in various social contexts and through a number of symbolic practices" (1). Gender identity is, therefore, also something that is developed and reestablished through different symbolic practices. One of those practices can be a narrative, which can both constitute and naturalize different concepts such as gender. This in turn means that narrative can also be used as a tool to dismantle stereotypical representations of gender.

In her many novels, including *Love Medicine* and *Tracks*, Louise Erdrich uses her narrative style and creates a rich variety of characters to deconstruct some of the existing Western concepts of gender and bring to focus a diversity of possibilities of a person's identity within patriarchal societies and structures. Many critics suggest that most of Erdrich's major characters seem to be walking a blurred line between two genders. Barak, for instance, describes Erdrich's characters as "gender-mixed" due to their actions that sometimes resemble opposite sex role behaviors (51). When reading about Erdrich's female characters, one often encounters themes related to motherhood and pregnancy, adoptive parenthood, or the role of a woman within the family and in the society. On the other hand, significant female characters also exhibit traits that are usually attributed to men, such as physical strength and rougher appearance, boldness, interest in "male" activities like hunting, working in a butcher shop, or playing cards. Accordingly, Erdrich's writing resists typical categorizing and definite representations of women's identities, and is instead a representation of diverse cultural identities. Different critics claim that, when creating these fluid gender identities, Erdrich actually draws on Native American tradition and its gender roles that are available to her through her own mixed background. These roles are rooted in powerful figures of Indian

mythologies, figures that are full of oppositions and contradictions such as the *berdache* (Barak 51) and the *trickster* (Cox 19, Rosenthal 5), as will later be demonstrated through the detailed analyses of several female characters. Moreover, Erdrich's work itself can be characterized as a "trickster discourse" – a multi-layered set of narratives that play with oppositions in which the *trickster* figure appears "both in the creation of her female characters and as a narrative device" (Rosenthal 2). The following chapters will explain the concept of *tricksterism* and discuss how it can be applied to Erdrich's work. They will also describe the characteristics of the *trickster* and the *berdache* in general before moving on to the analysis of particular female characters that bear resemblance to those figures.

### **3.1. The *Berdache* Concept**

In her article "Blurs, Blends, Berdaches: Gender Mixing in the Novels of Louise Erdrich" Julie Barak argues that Erdrich's gender-mixed characters are based on the powerful Native American figure of *berdache*. This figure is described "as a person, usually [but not exclusively] male, who was anatomically normal but assumed the dress, occupations and behavior of the other sex to effect a change in their gender status" (51). In many North American tribes *berdaches* enjoyed a special status and were recognized as highly valuable individuals in the community. They performed a wide range of tasks, since they excelled in both female and male activities, and their ability to perform both roles made them special within the community. It was believed that these people had special talent in educating, assistance during childbirth, healing wounds and insanity, as well as in spiritual practice. Furthermore, they were the makers of love medicines and were believed to have extremely active sex lives. They were also perceived as match-makers, called upon to give names to children, or to oversee funeral rites. They usually had a long and lucky life (Barak 52).

The female version of a *berdache* is often referred to as a "manly-hearted woman," and some of her common characteristics are independence, ambition, pronounced sexuality, aggressiveness, and maturity (Barak 52).

All these attributes can be recognized in Erdrich's characters. For instance, Marie Kashpaw in *Love Medicine* demonstrates at first her spiritual ambition when she enters the convent to dedicate her life to a spiritual path. Later, however, she displays the same trait in showing significant interest to climb a social ladder within the community by making her husband Nector a tribal chairman. Lulu Nanapush is another embodiment of the *berdache* traits. She is a character of evident sexuality and promiscuity, with an inexplicable influence on men. She has sexual affairs with various men and gives birth to nine children of different fathers, thus further reinforcing her influence in the community, and she is even ready to boast about her escapades. She is the true impersonation of manly-hearted women, who are also "reputed to be *ikitaki*, passionate women, and their sexual unconventionalities are the subject of much gossip" (Barak 52). Marie, Lulu, June, and Fleur are all women of strong desire for independence. In *Tracks*, Fleur is probably the strongest and most independent character. She earns her own money in the butcher shop, wins in playing cards; she is a healer and an excellent hunter; she is big and strong, provides for herself, and uses her spiritual superiority to save herself from drowning on several occasions, sending men to death in her stead. June, on the other hand, strives for independence, but does not succeed at fully achieving it, failing at different jobs time and time again.

Erdrich's novels are not only open to reconsideration of gender roles, but also to blurring of other boundaries. For example, numerous characters are either ethnically mixed or it is very hard to trace their family relationships, which are quite intertwined. Furthermore, some characters are not just in-between gender roles but are also in-between the human and the animal, or the human and the spiritual worlds. Fleur, for example, is described as fishlike and

is believed to shift appearance into a bear. Similarly, June's drunken husband, Gordie, runs into a deer with a car and is convinced that he had in fact killed June. To a regular reader it might seem that Gordie is just hallucinating, but a Native reader might consider a possibility that the deer may in fact have been June's spirit. By creating these characters that are hard to be classified, Erdrich plays with different borders and limitations in the reader's mind, refusing to fit her characters into any specific mold. This leads to an obvious connection with yet another Native American traditional figure – that of the *trickster*.

### **3.2. The *Trickster* as a Character**

Among many descriptions of the *trickster*, the most concise and at the same time the most complete one might be the one by Paul Radin:

Trickster is at one and the same time creator and destroyer, giver and negator, he who dupes others and who is always duped himself . . . [dominated by] impulses over which he has no control. He knows neither good nor evil yet he is responsible for both. He possesses no values, moral or social, is at the mercy of his passions and appetites.... (254)

Not many other myths have such a widespread distribution as the *trickster* myth. The *trickster* can be found and recognized in Native American tradition, but also among many other cultures – including Greek, the Japanese, the Chinese, many African cultures – and in the Semitic world. Landay describes him as "an unruly, contradictory figure who appears in virtually every human culture" (542). Brehm explains that in Anishinaabe oral tradition this figure is known by different tribes as Wenabojo, Nanabozho, Manabush, or Nanabush (683). He does not possess any particular fixed form; he can be identified with various animals, supernatural beings, but he is primarily "an inchoate being of undetermined proportions, a figure fore-shadowing the shape of man" (Radin 254). He is a "shape-shifter . . . the world's oldest, and newest, creation" (Smith 1).

*Trickster's* behavior is frequently considered antisocial, for it transcends the usual and comfortable social restrictions. He possesses the ability to live in-between categories, to escape the structures of society, and therefore he resides as an outsider in the liminal or marginal space. Barbara Babcock explains these concepts:

"Liminality" means midpoint in a status sequence, betwixt and between all fixed points of classification and, therefore, structurally if not physically invisible. . . ."Outsiderhood" means inhabiting a state permanently outside the social structure . . . contrasted with "marginals". . . who are members of two or more groups, who are also "betwixt and between," but who, unlike "liminals" have no guarantee of the resolution of their ambiguous state. . . . Tricksters . . . may, in their various guises, emerge from or imply any or all of these "antistructural" states, generally shifting from one to another in the course of the narrative. (156)

She further explains that these deviant forms of behavior are not just tolerated in the society; moreover, they are in fact needed and the social organization would be impossible without them. The reason for this is the fact that all systems are defined in terms of what they are not, meaning that the marginality is not only a by-product of those systems but also their defining condition (157).

In Erdrich's novels specifically, this in-between marginal area is the boundary of two cultures, Native American and Catholic, where the characters of the novels live and combine different parts of both cultures, thus creating a new society, a new culture out of the conflict of races and traditions. As a result of this marginality of cultures, some characters become the *tricksters*, with dual social connections and even dual personalities, as it will later be demonstrated by specific examples of Erdrich's characters.

Babcock, Landay, Radin, Smith, and many other critics describe some additional attributes of the *trickster*. He represents double or more meanings on different levels. He is a

vagabond, independent from temporal and spatial boundaries, not linked to any specific space; he often lives in caves, on the crossroads, underground, or in open public and undefined social spaces. He blurs the distinction between illusion and reality; he negates and violates the customs and is therefore unpredictable and illogical. He is characterized by mental or physical abnormality, or even both, exaggerated sexual characteristics and an enormous libido. He is always ambiguous and double – he can be of uncertain sexual status, young and old at the same time, creative and destructive, situated between life and death, or good and evil, and can display human/animal or human/spiritual dualism. He also has no sense of moral and social values and is at the same time central and marginal to the culture. He is an embodiment of contradictions of our existence, such as the opposition between the individual and society, or freedom and constraint, and as such he often enjoys privileged freedom that is not available to those who blindly obey the restrictions of social codes (cf. Babcock 159-63, Landay 542, Radin 253-56, Smith 1-2).

According to Smith, as such a mythic figure the *trickster* can play an important role in building and transforming a culture (2). This is why these characters have a high chance of appearing in cases when the values of a culture are threatened in some way, as is the case with Native American culture in Erdrich's novels. *Love Medicine* and *Tracks* both incorporate the themes of cultural hybridity – a blending of Native American and Catholic tradition. There are mixed blood characters, like Pauline, who rejects her Native American side and attempts to completely embrace Catholicism, although throughout the novel we can see that she actually does believe in traditional Anishinaabe medicine – the source of Fleur's powers. On the other hand, some Anishinaabe characters start to embrace parts of the Catholic tradition in one way or another. One of many examples for this is Marie Kashpaw who, although of Native American origin, goes to the Catholic convent as a girl to become a nun and dedicate her life to a religion that she was not originally born into. However, she eventually leaves the convent



and goes back to her culture, but sometimes, just sometimes, she still secretly holds the sacred beads in her hand, which is a reminder and a connection to the time she spent immersed in the Catholic tradition. This goes to prove that individual and communal identity are not completely fixed and that they can be influenced and reinvented due to the effect of many factors. In cases like this, as Wiget suggests, the *trickster's* function is "not so much to call cultural categories into question as to demonstrate the artificiality of culture itself" (94).

### **3.3. Louise Erdrich's Narrative Tricksterism**

To further accentuate the blurred lines between genders, races, and cultures, Erdrich uses not only the character of the *trickster*, but she herself, as well as her whole narrative, takes the role of the *trickster*. Explaining the nature of the *trickster* narrative, Gerald Vizenor emphasizes: "Nanabozho, the woodland tribal trickster, is a holotrope, a comic holotrope, and a sign in a language game; a communal sign shared between listeners, readers and four points of view in third person narratives" ("Trickster Discourse..." 187). These four points of view are the author, narrator, characters, and the audience, and they are all together the comic holotropes in trickster narratives. The comic holotrope is a consonance of narrative voices in discourse. The trickster can, therefore, be seen as a "comic discourse," a collection of "utterances" in oral traditions, and each utterance is the product of the interaction of the interlocutors. As a result of the *trickster's* elusive and ambiguous nature, the meaning of a story can only be created through all these points of view combined together. According to Vizenor, the reader has a crucial role in recreating a story, because "the active reader implies the author, imagines narrative voices, inspires characters, and salutes tribal tricksters in a comic discourse" (*Trickster of Liberty* x).

If this theory is applied to Louise Erdrich's novels, it becomes apparent that she, as the author, becomes the *trickster* in telling her story. She creates several different perspectives,

seven in *Love Medicine* and two in *Tracks*, as each chapter is narrated by a different character, mostly from a first-person perspective, although some chapters in *Love Medicine* are also told from the limited third-person perspective. This kind of storytelling is typical of Native American oral traditions. By employing this narrative technique, Erdrich "blurs the boundaries between self and other, between male and female, between the real and the fantastic, and even between story and audience" (Smith, *Writing Tricksters* 21). This can be perceived in *Tracks*, where Erdrich employs two first-person narrators, Pauline as a "neurotic nun" and Nanapush as a "*trickster* grandfather" (Adamson Clarke 37), leaving the audience the choice of choosing which narrator's version is more credible. Nanapush has the literal first and last words (chapters One and Nine), but other than that there is no structural privileging of either narrator – "[s]ometimes they contradict each other . . . at other times they support, supplement, or exemplify each other's tales despite themselves" (Hassel Hughes). Using this strategy, Erdrich can distance herself from any position that she might take as the writer and the actual storyteller, thus also accentuating the uncertainty of a story, demonstrating that there can be different versions of a story, and never just "one true telling" (Adamson Clarke 37). In *Love Medicine* narrative multiperspectivity is even more accentuated, as the author offers several different interpretations of the story through as many as seven narrators.

The storytelling of this kind does not impose any moral restrictions, but rather offers a communication between the individual and the community, and between the teller, the tale, and the audience. In Erdrich's novels, the closures are open-ended and contradictory, and the characters are in a dialogue with the reader, allowing the reader to see the same story from different angles and fill in the gaps in the storyline. In that way the reader has to play a more active role in order to construct the meaning of the story, which equips him, as Smith explains, with a deeper understanding of cultural boundaries and a better ability to cross them (*Writing Tricksters* 24).

Erdrich writes her novels in episodes, which are not always obviously connected and are told by different narrators and at different points in time. This is a typical organization of *trickster* tales, as the narrative crosses the boundaries of space, time and action or plot. Babcock argues that this lack of unifying elements is not a sign of a lack of structure, but quite the opposite – it signifies an "antistructure" that "implies structure and order" (167-68). Babcock further explains that this kind of narrative structure points towards the *trickster* cycle, defining a cycle as "a number of narratives centering about a hero or group of heroes and forming a continuous series" (168). This is really so in Erdrich's novels; both narrators in *Tracks*, Nanapush and Pauline, center their stories around Fleur's life, and in *Love Medicine* most stories and different characters are in some way connected to June Morrissey, even if that is not obvious from the first moment. Both novels represent a community and comprise several different episodes centering on one character, or in June's case, implying one character. This shows that there is a structure that goes beyond the level of episodes and that these episodes are not random, but rather carefully embedded into a whole of Erdrich's novel, or even an entire series of her novels. This is especially apparent in the case of Lulu Nanapush, whose character has one of the central roles in *Love Medicine*, but becomes much more complete once the reader also becomes familiar with her character as a young child in *Tracks*.

As Erdrich herself is of a mixed ethnic background, she writes from a point of view between two cultures, and her storytelling can be viewed as a way of coming to terms with that background. She believes that a person's ethnic background is something that you "cannot simply walk away from" (Rosenthal 109), but also that being mixed blood means having a choice, in a certain way, of which group you want to belong to. Therefore, this position is enriching rather than depriving. Her fiction draws on both cultural backgrounds in the content and in the narrative of her stories – she uses Chippewa narrative devices and postmodern

narrative techniques at the same time. This too can be seen as a *trickster* strategy since *trickster* is known as the enemy of boundaries that has the ability to straddle different cultures and worldviews (cf. Babcock 182). Similarly, Erdrich's narrative *tricksterism* moves from one cultural context to the other one, mixing Native American and Catholic traditions. Her *trickster* authorial and narrative stance enables her to transcend racism and sexism in her stories, and not just to document them. In that way she brings to focus and challenges the artificiality of boundaries between cultures, races, and gender.

### **3.4. Louise Erdrich's Female Characters as *Tricksters***

While some critics claim that in a number of Native American *trickster* stories gender matters, that narrating *trickster* stories are mostly associated with men, and that even in those tribes whose *trickster* stories have female protagonists, such stories are apparently in the minority (Ballinger 5, 16), others may argue that the *trickster* "is not a pawn in a power game between sexes" (Cox 20) and that the overlap of *tricksters* and women in Native American literature offers too much material to ignore a woman's existence as a *trickster*. Furthermore, Wiget considers the female *tricksters* easily found in Native American literature, and argues that their presence does not depend on the sex of either the storyteller and audience or a particular context. He claims that in traditional Native communities "a female trickster was a commonly understood, unexceptional figure whose character is contrasted with that of the male" (89). According to Smith, the lives of Native American women cross so many borders that it is likely to find the best models of *trickster* strategy among them (*Writing Tricksters* 28). These women, Erdrich among them, who have been discriminated both due to their race and sex can combine their cultural interest in challenging racial stereotypes with the feminist interest in the deconstruction of gender stereotypes and patriarchy.

The narrative forms and characters of *Love Medicine* and *Tracks* emphasize the variety and continuance of the culture they represent, instead of reinforcing the existing Western stereotypes towards Native women. Erdrich distributes intriguing, ambiguous female *trickster* characters such as Fleur or Lulu all over her novels, and not just as characters but also as some of the most important narrators with a strong influence on the reader's perspective on the story, as is the case with Lulu and Marie. Erdrich's writing tackles the issues that do not fit into the norm of typical Western gender codes. Her female characters are capable of transgenderation tricksterism; they draw both on the feminine and the masculine, and they are the ones that survive in the novels and carry on with their stories, the ones that represent them as strong, remarkable characters. These characters appear in more than one of Erdrich's novels and their identity is often shaped through intratextual references. Since such characters are transgendered, Erdrich uses them to re-appropriate the masculine attributes, and for this reason some of the female characters can be seen as "feminist revisions of the trickster" (Smith, *Writing Tricksters* 29).

### 3.4.1. Physical Appearance

*Trickster* is a shape-shifter; he or she is of undetermined proportions, mostly described as a figure that does not possess any fixed form in particular. Regardless of distinctive physical features that include tail, paws, scent, and mysterious animal tracks that are left on the ground, the figure suggests the shape of a man and it is understood as a human character, one that can change the external appearance at will and manipulate the body in marvelous ways (Wiget 87).

Of all Erdrich's female characters that bear resemblance to the *trickster*, perhaps the one that resembles this figure the most in the physical sense is Fleur Pillager. Although she is obviously a woman, her body brings together both male and female properties, just like those of a *berdache*. She is strong and big, and that is precisely the reason why she is hired for a job in a butcher shop at the beginning of the novel, a job that requires physical strength and abilities usually found in men. Despite these typically male attributes, men still find her highly attractive and seem to be unable to resist her female allure, which is more than obvious in the way she moves and behaves. Pauline as a narrator notices that Fleur "knew the effect she had on men, even the very youngest of them. She swayed them, sotted them, made them curious about her habits, drew them close with careless ease and cast them off with the same indifference" (*Tracks* 16–17). Fleur's blood carries the power of her family, and this power comes down through hands, which are in Pillagers "strong and knotted, big, spidery and rough, with sensitive fingertips good at dealing cards" (*Tracks* 31), and it also comes "through the eyes, belligerent, darkest brown, the eyes of those in the bear clan, impolite as they gaze directly at a person" (*Tracks* 31). Pauline sees and envies Fleur's looks and abilities, but the men in the butcher shop are ignorant about it and are only attracted to her physically.

Besides her transgender qualities, Fleur's physical qualities also reveal her *trickster* nature by crossing the human/animal boundaries, and she is several times throughout the novel described as a combination of different beings from traditional stories:

Her cheeks were wide and flat, her hands large, chapped, muscular. Fleur's shoulders were broad and curved as a yoke, her hips fishlike, slippery, narrow. . . . Her glossy braids were like the tails of animals, and swung against her when she moved, deliberately, slowly in her work, held in and half-tamed. But only half. I could tell, but the others never noticed . . . her sly brown eyes or her teeth, strong and sharp and very white. Her legs were bare, and since she padded in beadworked moccasins they never saw that her fifth toes were missing. (*Tracks* 18)

With all these features, as Joni Adamson Clarke notes (32-33), Fleur brings together several Chippewa myths of transformation. The description of her teeth matches the traits of the mythic Wolf of traditional Chippewa stories, who is sometimes the grandson and sometimes the underworld brother of Nanabozho, the compassionate woodland *trickster*. Similarly, at the age of seventeen, after her family has been killed by a sickness, Fleur is adopted and taken care of by Nanapush, Erdrich's *trickster*/healer figure reminiscent of Nanabozho. At other times, Fleur's glossy braids resemble the tails of animals, while her skin is described as "skin of lakeweed" (*Tracks* 18), which in combination with her thin, green dress makes her look like Misshepesshu, the water monster. In Chippewa tradition, according to Adamson Clarke (33), Misshepesshu was believed to be the underworld protector of Wolf and to cause death by drowning. Taking into consideration her wolf-like grin, as well as the fact that several times she managed to escape drowning in the lake, Fleur obviously not only resembles Misshepesshu physically but also enjoys his protection, just as the Wolf does.

Fleur's bodily ambiguity and resemblance to Wolf and Misshepesshu give her great power, which is further accentuated through her even more frequent association with a bear.

She belongs to the Pillager family, which is of the bear clan. Its members live beside Matchimanito Lake, the dwelling of the Misshepeshu. A penetrating gaze and a wolf grin are their most recognizable characteristics, as are their medicine power, which "travels in the bloodlines, handed out before birth" (*Tracks* 31), and their knowledge of "secret ways to cure and kill" (*Tracks* 2). Pauline reveals why people believed that Fleur was even able to literally shape-shift into a bear:

We know for sure because next morning, in the snow or dust, we followed the tracks of her bare feet and saw where they changed, where the claws sprang out. The pad broadened and pressed into dirt. By night, we heard her chuffing cough, the bear cough. By day her silence and the wide grin she threw to bring down our guard made us frightened. (*Tracks* 12)

According to Adamson Clarke, a bear is simultaneously a symbol of both life and death as a result of the life cycle typical of this animal – circling between hibernation during winter and awakening in the spring (33-34). That taken into consideration, Fleur's connection to a bear enriches her character with yet another ambiguity, placing her into a liminal space between life and death, which is reinforced by her other traits. Furthermore, Baker Barry reminds that "strength is bear's most outstanding characteristic in this mythology, and bear, along with wolf and lynx, is an important totem to warriors" (25). This explanation amplifies Fleur's ambiguity regarding gender, placing her into the marginal space between both genders and into the category of the *berdache*. Created with the combination of these mythological figures, Fleur seems almost demonic. Adamson Clarke describes her as "a visual pun who disorders the boundaries between human and animal" (28). Through the character of Fleur, these powerful creatures are related to female power and survival, deconstructing the stereotype of a weak and helpless Native woman. Since the *trickster* is seen by many critics as a textual sign, here Fleur becomes "a sign for paradox" (Rosenthal 142) and thus breaks the existing gender codes. With all these traits, Fleur can be read as a point in which several intertextual



discourses meet, which causes constant shifts in the meaning of her character. And indeed, her changing body, her androgynous features, as well as her unusual behavior, make her identity highly fluid and hard to grasp, just as the text of the novel itself.

The bodies of other female characters do not reveal such strong and obvious physical features of the *trickster*, but there are some indicators that can unmistakably relate them to this intriguing figure. June's appearance, for example, fails to directly connect her to any of her blood relatives, making her identity elusive – a property which obviously gives her a trickster quality. Her full name is June Morrissey Kashpaw, but she is a daughter of Lucille Lazarre and Morrissey I. Lucille was an abusive alcoholic, and according to the chapter "The Beads" in *Love Medicine*, June was alone with Lucille when she died in the woods (*Love Medicine* 63). She was found by her drunken father and taken to raise by her mother's adoptive sister Marie Kashpaw. This is how Marie describes her:

I saw nothing, no feature that belonged to either one, Lazarre or Morrissey, and I was glad. It was as if she really was the child of what the old people called Manitous, invisible ones who live in the woods. I could tell, even as I watched, that the Devil had no business with June. (*Love Medicine* 65)

This passage clearly demonstrates that June was seen as someone undefined even by the other characters of the novel.

*Love Medicine's* first chapter "The World's Greatest Fishermen" opens up with an image of June in 1981 while she is walking down the street in Williston, North Dakota, waiting for the bus to take her home to the reservation. She is described as "a long-legged Chippewa woman, aged hard in every way except how she moved" (*Love Medicine* 1). In this single sentence, the author portrays June as a union of an aged body and a touch of something young – her body movement which evokes the youth of her spirit and tricks the observer, making one uncertain of her actual age. This goes to show that June indeed is the *trickster*, for

this figure is "indeterminant (in physical stature) . . . as both young and old . . . perpetually young . . . perpetually aged" (Babcock 163). The reader sees June for the first time through the male gaze: "Probably it was the way she moved, easy as a young girl on slim hard legs that caught the eye of the man who rapped at her from inside the window of the Rigger Bar" (*Love Medicine* 1). The man invites her to join him and so she does. As she enters, the writer connects her skillfully with the basket of colorful Easter eggs on the counter of the bar, the man is peeling a sky blue egg as she enters, and what she "walked toward more than anything else was that blue egg in the white hand, a beacon in the murky air" (*Love Medicine* 2). As she sits next to him, the man peels another egg for her, a pink one, the same as the color of her turtleneck, saying that "he would peel that for her, too, if she wanted" (*Love Medicine* 2), and then hands her the naked egg. June's sexual exploitation is metaphorically made obvious in this way. Her connection to the pink egg that the man is peeling suggests that he finds her easy and cheap. June changes her plans of going home on the next bus, half believing that the ticket will be valid forever, and she follows the man into several bars, thinking that maybe this man could be different compared to her previous lovers. As we read on, June seems disoriented and frail, especially when she walks into the bathroom stall:

Walking toward the Ladies she was afraid to bump against anything because her skin felt hard and brittle, and she knew it was possible, in this condition, to fall apart at the slightest touch. She locked herself in the bathroom stall and remembered his hand, thumbing back the transparent skin and crackling blue peel. Her clothing itched. . . . All of a sudden she seemed to drift out of her clothes and skin with no help from anyone. . . . She felt that underneath it all her body was pure and naked – only the skins were stiff and old. Even if he was no different, she would get through this again. (*Love Medicine* 4)

This passage suggests that June knows very well what is about to happen, she foresees and accepts the situation in which she is going to crack, just like the egg. However, the feeling of her body being naked and pure may also indicate that she will transcend that situation in some

way. It is almost as Erdrich allows here, even if only to the most insightful reader, a foreshadowing of June's death at the end of the chapter. Erotic insinuations eventually prove correct when June finally has sexual contact with the man in his car, even though he is too drunk and he just moves his hips against her while moaning some other woman's name, and afterwards falls asleep. She waits until she starts feeling frail and afraid of cracking open again, and then slips out of his car into the cold: "It was a shock like being born" (*Love Medicine* 5). Although the cold is harsh and unbearable, June decides to walk home, and does not give up on what she had intended even when it starts snowing, which eventually leads to her death, thus carrying out previously described Erdrich's game of foreshadowing:

Even when her heart clenched and her skin turned crackling cold it didn't matter, because the pure and naked part of her went on.... The snow fell deeper than Easter than it had in forty years, but June walked over it like water and came home. (*Love Medicine* 6)

It is interesting that June's actual physical presence occupies only this first chapter of the novel. Her death, which is the central topic of the opening chapter, removes her physical body from the novel. Yet, she remains an important character throughout the entire book. After this first chapter, she does not participate actively in the creation of her own story and does not have her own voice; she is rather painted through different perspectives of the stories that other major characters tell about her, all of whom are connected to her in one way or another. As Rosenthal explains, "June's life and the enigma of her death are the driving forces behind the narrative throughout *Love Medicine*: she rises from the stories the community tells about her in the same way the community defines itself through her" (113).

As we can see, and as Smith effectively confirms, Erdrich applies the concept of a fluid identity not just to her characters' personalities but also, in physical terms, as characters shape-shift and cross the limits of their bodies, stopping even death from defining or

destroying them (74). Those characters with an impalpable ability to dissolve their physical limits, like Fleur and June, are the ones with the strongest *trickster* identities.

### **3.4.2. Character, Personality, and Social Status**

Contrary to the Euro-American cultures which have defined and binary gender distinctions, traditional Native communities were more prone to defining gender according to behavior and occupation, rather than mere biology or sexual choices. Ballinger explains that it was not unusual for Native cultures to recognize not only male and female, but also "Two-Spirit womanly males and Two-Spirit manly women" as genders, also known as *berdaches* (30). They had the ability to reject dualistic gendering and accept gender boundary transgressions, which would be seen as ambiguous or unacceptable in Euro-American cultures. A young woman could become a Two-Spirit if she displayed what was considered as typical male behavior, interest in men's work and keeping company with men: "Trickster's occasional transgendering adventures comically demonstrate the inadequacy of what seem to be natural gender expectations but which are, in fact, artificial – that is to say, only human – boundaries. Trickster prepares us for the necessity of Two Spirits" (Ballinger 34).

All of Erdrich's female *trickster* characters display some kind of "male" behavior and/or interest in "male" activities. Fleur is a seventeen year old girl in the first chapter of *Tracks* when her parents' and siblings' lives are taken by an epidemic and Nanapush rescues her. The Pillagers used to live beside Matchimanito Lake, so after surviving the harsh winter, Fleur returns to live on her own in her family's cabin "that even fire did not want" right next to the lake where the water monster resides, and "a young girl had never done such a thing before" (*Tracks* 8). Among the Dakota tribes, *tricksters* and *berdaches* usually lived outside the camp or on its borders, in unconventional places, and this lodging indicated their marginal position within the community. Cox draws a comparison between Silko's Yellow Woman-

type and Fleur, who retreats to the margins of the lake so that she can choose lovers at her will, raise her daughter Lulu as she pleases, and fight against the lumber company that threatens tribal unity (19). According to Pauline, Fleur "messed with evil, laughed at the old women's advice and dressed like a man;" she even "got herself into some half-forgotten medicine, studied ways she shouldn't talk about" (*Tracks* 12). Fleur also has excellent hunting and trapping skills, and these activities are more common for men than for women. She is her own master. Moreover, Fleur goes hunting out of her own body, in a shape of a bear, as was described earlier.

Fleur is very determined to keep the Pillager land when the lumber companies and the Government fee collectors come, so she goes to Argus to work in a butcher shop, where she is observed by Pauline Puyat, one of the two narrators in the novel. Since this kind of a working place is usually under male dominance, Fleur's presence there is sort of an intrusion, but she especially breaks gender codes when she joins her fellow employees, all men, in poker games. Fleur is cunning and uses the men's overconfidence and feeling of superiority against them. Every time she pretends that she does not know how to bluff, the men think that this is typical of a woman, and she always wins just one dollar, feeding their egos and feelings of superiority. Thinking that she does not have the nerve to bluff, one of the men says: "Well, we know one thing . . . the squaw can't bluff" (*Tracks* 20). Erdrich uses specific vocabulary to blend sexist and racist prejudice; the word "squaw" demonstrates that the men discriminate against Fleur not just due to her sex but also due to her race. They find it hard to believe that "a woman could be smart enough to play cards, but even if she was, that she would then be stupid enough to cheat for a dollar a night" (*Tracks* 21). Fleur fools the men in this way for a week, and they are irritated by her winnings despite her apparent inability to bluff. Moreover, they are upset and disturbed because, in some way, they can notice that Fleur threatens their superiority. Eventually, Fleur bluffs a bluff; the men walk into her trap and lose all their

money. Fleur takes the money and walks away from the table yawning, showing no regrets. After this, the men rape Fleur, but the real reason might not be the money. For them, it is a way of regaining their superiority and minimizing their humiliation and embarrassment due to the fact that a woman, "a squaw," had outwitted them at playing cards, the field they considered to be under their dominance. The idea that "a squaw" was cunning enough to drag them into her trap for an entire week and finally beat them at their own game, poses a threat at many levels, and crashes both their sex- and race-related stereotypes. The next day Fleur disappears, and a hurricane hits the town. The three men are found only three days later, locked in the meat lockers, positioned around the barrel with the laid out game of cards, frozen to death, wrapped in bear furs. According to Rosenthal, "Considering that Fleur is often described as 'bear,' with her laugh reminiscent of a bear cough and the bear tracks she leaves when hunting, it looks like she has met her prey in the meat lockers" (139). This entire episode demonstrates how, from the very beginning, Fleur wisely uses the men's racist and sexist prejudice against them. It also shows Fleur in the light of a victim and a powerful avenger at the same time, a contradiction typically contributed to *tricksters*.

Ballinger points out that although the *Two-Spirit* people enjoyed high status, the attitude of the society towards gender crossing and living as a *Two-Spirit* was ambivalent (31). These gender crossing *tricksters* were valued and respected, but also feared due to their supernatural power because they often chose to live in a way that was considered abnormal, or at least unusual. Fleur has been respected, but also feared and gossiped about all her life in the community (cf. Barak 56). She is a healer; she knows the old ways and is respected because of that, but still remains an outsider. According to Rosenthal, Fleur "feeds the imagination of the community;" she is "the center and at the margin of the community at one and the same time" because she is "the definitive force behind the community as well as a contrastive element"

(126). She is described as a powerful and dangerous woman, and most people are afraid to approach her:

Men stayed clear of Fleur Pillager after the second drowning. Even though she was good-looking, nobody dared to court her because it was clear that Misshepeshu, the water man, the monster, wanted her for himself. He's a devil, that one, love hungry with desire and maddened for the touch of young girls, the strong and daring especially, the ones like Fleur. (*Tracks* 11)

The community does not understand Fleur, and therefore they fear her, because she has no fixed identity; she is something in-between: a link between male and female, human and animal, body and spirit, life and death, reality and fantasy. Some people are so upset about her unusual character and behavior that they even want her to leave the reservation. Her exceptional and abnormal behavior, in between many possible opposing forces, can be looked upon as a manifestation of the limits of social boundaries, and as such it poses a threat to its established order and to constructed stereotypes. Adamson Clarke supports this statement, as she explains that Fleur's

anomalous actions are interpreted as a dangerous questioning of accepted social order because they de-form the continuously repeated traditions which have established what is considered normal or natural in her community; by failing to repeat those traditions, Fleur, like the "liminal monsters"... reveals the freedom, the interdeterminacy underlying all culturally constructed worlds. (34)

After her family's death, Fleur is taken care of by Nanapush, who even gives her his name, which is one of the linguistic variants of the name of the Chippewa *trickster*. Barak and Baker Barry both duly notice that Fleur has heirs to her power, and that she even passes the Nanapush name to her descendants, thus creating an entire family of *tricksters* (Barak 57-58, Baker Barry 34). The first of them is her *trickster* daughter Lulu Nanapush, followed by Lulu's son and the contemporary *trickster* Gerry Nanapush, Lulu's son and entrepreneur

Lyman Lamartine, and dreamy, vision-seeking Lipsha, the son of Gerry Nanapush and another female *trickster*, June Morrissey. Fleur thereby connects Erdrich's novels and the characters within them. She is the central character in *Tracks*, and although she does not appear in person in *Love Medicine*, she is an absent presence through her bloodline. After reading both novels and discovering all the blood relations between the characters, the reader can literally feel Fleur's floating presence in *Love Medicine* through those characters. Lipsha carries in his blood traces of Fleur's power, and he also has the gift of healing, and even makes a clumsy attempt to make a love medicine for Nector and Marie Kashpaw. This also shows how, compared to Fleur, the younger generation has lost the real knowledge of the old ways. Unlike Lipsha, Fleur knows and understands the old traditions and magic, and she is mentioned in *Love Medicine* when these traditions are involved. Therefore, in this novel she "serves as a subtext for the forgotten yet lurking powers of the Chippewa" (Rosenthal 129).

Fleur is also described as seductive, irresistible to men, and with the exception of the scene in which the men are the aggressors, she "exudes sexual power" always as "the hunter and never the prey" (Van Dyke 133). Despite her sexual allure, Fleur remains focused on her partner Eli Kashpaw throughout the larger part of the novel and they only separate during a period of time after he is tricked by Pauline into cheating on Fleur. Her daughter Lulu, however, displays her sexual promiscuity in more open ways, and that is the *trickster's* quality which is the most prominent in her character. Lulu's childhood is recorded in *Tracks*, but we meet her as a grown woman in *Love Medicine*. She is the mother of eight sons, including Gerry Nanapush, Henry Lamartine Junior, and Lyman Lamartine, and only one daughter, Bonita. During her life, Lulu has several husbands and several lovers, and all her children have different fathers. Her first and never forgotten love, however, is Nector Kashpaw, who actually might be her uncle. Although he marries Marie, Lulu later has an affair with him, which results in the birth of their son Lyman. Due to all this, Smith draws a comparison



between Lulu and Nanabozho's grandmother Nookomis, and sees Lulu as "Erdrich's feminist revisioning of the trickster, sharing Nanabozho's physical flexibility, artful gambling, and sexual prowess" (79-80). Lulu is the one to whom Nanapush tells his stories in *Tracks* in an attempt to recreate a sense of a family and tribal history and community for her. His success can be tracked all the way through Lulu and her nine children, because she herself actually plays an important role in repopulating the reservation through different fathers.

Similarly to Fleur, Lulu's status in the community is ambiguous. Although her promiscuous escapades contribute to the repopulation of the reservation, this kind of behavior is nevertheless disapproved of in the community: "But most of her life Lulu had been known as a flirt. And that was putting it mildly. Tongues less kind had more indicting things to say" (*Love Medicine* 76). Therefore, as is the case with all *tricksters* and *berdaches*, Lulu lives proudly on the margin of the tribal community.

Lulu's counterpart, Marie Kashpaw, is a manly-hearted woman, too, although in different ways. She displays the *trickster's* tendency towards ambition throughout her life, at first spiritually, and later socially, as she manages to improve both her economic and social status by marrying Nector Kashpaw and turns him into an important man within the tribal community. In *Love Medicine* we find out that most of her time as a child Marie spent in the bush, only coming to town for school and Sunday Mass. At the Sacred Heart Convent school, Marie's teacher is Sister Leopolda, her own mother according to *Tracks*. Leopolda is persistent about driving the devil out of Marie:

She always said the Dark One wanted me most of all, and I believed this. I stood out. Evil was a common thing I trusted. Before sleep sometimes he came and whispered conversation in the old language of the bush, He told me things he never told anyone but Indians. I was privy to both worlds of his knowledge.

I listened to him, but I had confidence in Leopolda. She was the only one of the bunch he even noticed. (*Love Medicine* 43)

Leopolda eventually pours scalding water on Marie's back, and later Marie kicks her into the oven. Leopolda then stabs Marie's hand with a fork and knocks her out, but tells the other sisters that the wounds in Marie's hand are the stigmata, so sisters kneel and pray to her.

Sanders explains that, as she does not know who her real mother is, Marie creates a vision of herself due to a lack of sense of her own personal identity (4). This vision is "borrowed from the role model proscribed by the nuns, the Virgin Mother" (4). Likewise, the vision suggests Marie's hunger for power, as she strives to usurp Sister Leopolda's role. However, this self that Marie envisions does not at first display the Virgin's admirable traits, but rather images that are borrowed from Leopolda's sadistic and twisted behavior, and from stereotypical iconic images of saints. Marie, however, leaves the convent after the violent episode with Leopolda, and on her way down she meets Nector Kashpaw, with whom she ends up having a sexual encounter, and eventually marries him, although he actually wants Lulu Nanapush. Sanders views this chain of events as a symbolic loss of Marie's control and Nector's takeover of the narrative, as the scene of their sexual encounter is narrated by him (5). In this way she becomes an object, and loses power simultaneously with the loss of her virginity and narrative control: "Through sexual intercourse with Nector, Marie separates herself from her identification with the Virgin Mary; this separation from an old identity opens the way for a new identity: Mrs. Kashpaw, wife of the tribal chairman" (Sanders 5-6). Marie thus poses as yet another *trickster* by slipping from one identity to another, diametrically opposite to the first one.

Barry and Prescott correctly notice how Marie is one of Erdrich's strongest characters because her life is a blend of gender based traditions. The way she lives includes risk and transformation during the time she spends in a convent exploring her spiritual side and

searching for a vision, but later she abandons these ways and becomes a typical mother, dedicated to healing and householding . It is possible that the vision from her adolescent years that stems out of her clash with sadistic Sister Leopolda is the very thing that carries her on to her future, enabling her to integrate past and present. Marie practices the compassion that the vision teaches her as she takes in children without a mother and helps Lulu regain her sight, although this woman has been her rival throughout their entire lives.

Another female character who reveals *berdache* and *trickster* tendencies to cross gender boundaries is June Morrissey. Although she dies in the first chapter of the novel, the narrators of other chapters of *Love Medicine* unveil some parts of her story. Barak notices that June as a young child was in fact raised in *berdache* ways, but that she is unable to fully accept her mixed-gendered status (55). Although she was given to Marie Kashpaw to raise, June got along well with Nector's brother Eli Kashpaw, who was crazy about her, and after some time she chose to live with him instead. She is taught to trap and hunt by Eli; she even dresses like him when she is younger, and in many ways she is like a son to him. Marie describes June and Eli as being alike, thus attributing some masculine characteristics to her: "She was like me, and she was not like me. Sometimes I thought she was more like Eli. The woods were in June, after all, just like in him, and maybe more. She had sucked on pine and grazed grass and nipped buds like a deer" (*Love Medicine* 65). In fact, June is through the father figure of Eli connected to Lulu, whose mother was Eli's companion and sexual partner, so Eli might as well be Lulu's biological father.

Later in life, however, June seems to reject this role; she does not become like Eli, and seeks out some traditional female roles of a wife and a mother. Although they were raised side by side, June runs away with her cousin, Marie Kashpaw's son Gordie, marries him and together they have a son, King Howard Kashpaw, thus breaking the incest taboo. However, June does not seem to be completely comfortable with her feminine side either. Her marriage

with Gordie becomes unstable, on-and-off-again, and she is not exactly an embodiment of an impeccable mother figure to her son King either. At some point she has a brief affair with Gerry Nanapush, which results in birth of their son Lipsha Morrissey, but June refuses to raise him and instead gives him to her own adoptive mother Marie, failing once again at performing her role as a mother. Eventually, she leaves the reservation and, similarly to Fleur, spends her life astray from the Native American community, moving around, living in strange places and marginal spaces of two different traditions, even changing jobs and lovers who give her money. Through the course of her life she attempts different occupations generally related to the white world, such as a waitress, a beautician and a secretary, but fails at all of them. During this time, she reveals her *trickster*-like tendency towards sexual promiscuity by sleeping with different men who sometimes give her money. According to Ballinger, although a woman might have chosen to live without getting married or outside of her marriage, her ways would still be subjected to disapproval among the community members because rejection of traditional female roles would have meant rejection of the society's rules and the society as a whole (21). Similarly, nobody prevents June to walk away from her marriage and her children, but this decision is nevertheless frowned upon among the community members.

Although taking money in return for the sexual intercourse might seem as a role more often attributed to a woman than to a man in Western society, the promiscuity that June thereby displays is nevertheless an attribute that is tolerated more in men than in women. Yet, as she is a *trickster* Native woman, she lives according to her whims anyway and rises above that stereotype. Therefore, just like in the *trickster* stories, June at the same time fits the existing taboos and breaks them. She does not fit any stereotype; she fails at traditionally female roles, but does not completely embrace her *berdache* upbringing either, and she strays away from her reservation and traditional Native American ways, but fails to fit in the Western society as well. Barak, therefore, rightfully concludes that June is one of those

*berdaches* who are not comfortable with the gender mix inside themselves (55), while Barry and Prescott induce that "although she is apparently unaware of it, the chaos in June's life is the result of a fragmented gender identity."

Several critics, such as Barry and Prescott, Farrell, Rosenthal, and Sanders, agree that *Love Medicine's* Easter setting of the first chapter entitled "The World's Greatest Fishermen" is important because it immediately evokes the pull between Christianity and Native American tradition. The chapter's title reminds at the same time of Christ, who was able to feed a huge crowd of people with only two small fish, and the image of June's uncle Eli, a Chippewa fisherman. Also, the town of Williston, where we first encounter June, is a "capitalist Western setting" and a "male territory that calls up images of the frontier and the exploitation of the land as much as it does the exploitation of women" (Rosenthal 123), and in this setting a Native woman cannot be rendered as anything else but "other." June's character walks the line between these two cultures, but a sense of balance or spiritual unity remains elusive for her. She is constantly caught in between the two worlds, but although the way she lives is her own choice, she does not seem to be able to fully accept that nor deal with it. After June leaves Andy in the car and walks away into the storm, the description of June's death is not graphic and easily decipherable; instead, the images of her walking on water and arriving home suggest magic and miracles. June is defined through "risk, transformation, and death, the elements of men's ritual" (Barry and Prescott). Sanders skillfully notices that Erdrich "marries" patriarchal Christianity to Native American matriarchy as she "transforms the Biblical Christ walking on water to a drunken Indian woman journeying homeward" (14). However, June's inability to cope with the estrangement from her own tradition is evident even as her own feelings of fragility become more and more accentuated after she misses the bus that was supposed to take her back home. Finally, she ignores or misreads the signs of the upcoming snowy storm, and this estrangement from her culture literally kills her.

Farrell argues that "June's acceptance of white stereotypes of Indians and her eagerness for death in this scene should alert us to the possibility that, despite the claims of many critics, her death in the opening chapter suggests defeat rather than transcendence." However, as it was presented before, June maybe dies and disappears physically from the novel, but her spirit continues to live on through her connection and involvement with other characters, and her presence never really ceases to exist as others remember her and even define themselves with regard to her, as in the case of her son Lipsha, who searches for his true ancestry and identity throughout the entire novel. Rosenthal supports this interpretation, as she explains that Erdrich does not want to represent June as a typical vanishing Native woman, and therefore uses her death to lead her out of this liminal space between two traditions. Erdrich thereby turns June into a "present absence" (*Love Medicine* 123), not just throughout this novel but also in the other novels connected to it. She "vanishes from a reductive symbolic field" (Rosenthal 123) in a trickster-like fashion, just as she vanishes from the page at the end of the first part of the novel's first chapter. Finally, maybe it is Albertine's vision of June that supports more than anything else the theory of her survival through transcendence and her character of a *berdache* and a *trickster*: "She would be dancing if there was a dance hall in space. . . . Her laugh an ace. . . . Her amusement at both the bad and the good. Her defeat. Her reckless victory" (*Love Medicine* 35).

### **3.4.3. The Mother Figure and Fluid Identity**

The analysis that has been carried out thus far suggests that one of the quite possibly crucial aspects that shapes ambiguous *trickster*-like female characters in Erdrich's fiction is their uncertain ancestry. June, Lulu, and Marie are all women who are, due to circumstances, either completely or partially unaware of their bloodlines, which might be a contribution to their lack of identity concepts as "[one's] ancestors are crucial to the sense of identity and

belonging. They provide the foundation of a psychological and mythological life, which provides a defense against the tragedies that take place in historical time" (Tanrisal).

June is raised by Marie and Nector Kashpaw, but her real parents are Lucille Lazarre and Morrissey I. Similarly, Marie LazarreKashpaw never finds out that her real parents are Pauline Puyat (Sister Leopolda) and Napoleon Morrissey. Even the reader does not get any clues whatsoever regarding her ancestry in *Love Medicine*; it is in Chapter Six in *Tracks* where we find out that Marie's real mother is Pauline. Upon finding out that she is pregnant, Pauline wants to abort, but is finally forced to deliver the baby, whom she later abandons to join the reservation convent. Marie is at first taken care of by Bernadette Morrissey and her children who live in Bernadette's house with their Lazarre spouses, so Marie grows up believing that she is also a Lazarre, referring to Ignatius as her father. Unlike June and Marie, Lulu at least knows that Fleur is her mother, but her paternity is uncertain. Her father might be Eli Kashpaw, but also any of the men who raped Fleur in Argus.

According to Tanrisal, Erdrich's novels illustrate that "mythological and cultural continuity [are] supplied by two factors – a native tradition of storytelling and retelling the events in the history of people and the matrilineal nature of the Native American structure." The character of Nanapush, who passes his stories on to Lulu, demonstrates how storytelling is a means of survival for the tribal tradition and culture, but he also contributes to the survival of his people by acting as a mother to Fleur when she is the only survivor of her family. Unlike Euro-American societies, which are patrilineal, Native American cultures tend to be more matrilineal and they equate tradition with the mother. Tanrisal notes, however, that due to destruction of many traditions, Native Americans have frequently become motherless children. Therefore, it is the storytellers' duty to remind their people of their past and identities through storytelling. As Native American women have an important role in passing on their tribal traditions and cultural values through stories, it is no surprise, then, that both Lulu and

Marie as female *tricksters* are important narrators in *Love Medicine*, thus forming also the reader's view of Anishinaabe culture and people.

In spite (or because) of the fact that these female characters, with an exception of Fleur who is familiar with her ancestry, do not have full knowledge of their own parents and bloodlines, they all have another obvious trait in common – they are all, including Fleur, embodiments of good mother figures. In *Tracks*, there are two opposite types of mothers presented – Fleur as a full-blood Native mother is contrasted to the mixed-blood Pauline Puyat. As an addition to her ambiguous *trickster* figure of a strong woman who lives independently in the woods, sending others into death to save herself and shape-shifting into a bear while hunting, Fleur displays also the other, more feminine side of a caring and overprotective mother figure. She raises her daughter Lulu with love, despite that fact that she might be a product of the rape incident in Argus. Perhaps the event that demonstrates her maternal characteristics the best is the one when Fleur goes into premature labor with her second child. At the time, only Pauline and little Lulu are present. Lulu walks through the snow to look for Margaret's help, and her feet get frostbitten. Pauline, on the contrary, does not help Fleur at all, and the child is born prematurely and too weak. Pauline then tells about her vision in which Fleur goes to the death's road to gamble for the lives of her children with the men whose deaths she has caused. She loses the life of the newborn baby, but Lulu's life is saved. After that, Fleur grieves her baby's death; her power seems to weaken and she becomes overprotective of Lulu. Later in the novel, however, Fleur has to give up her daughter because their land is taken away and Lulu is not safe on the reservation, without a home and economic security. Therefore, Fleur sends Lulu to a government school to prepare her for the culture that the white people are imposing upon the Native Americans. Because of this, Lulu is hurt and angry, and even refuses to call Fleur her mother.



To accentuate even more the role of Fleur as a caring and warm mother, Erdrich contrasts her to Pauline, who is everything opposite of a caring mother. Although both Fleur and Pauline are orphans, Pauline acts in a completely different way in comparison to Fleur. She does not want to have her child after she is left pregnant; she attempts to get rid of it in various violent ways, and, when Marie is finally born, Pauline gives her up, renounces her Indian identity completely, and takes the name Sister Leopolda to become a part of a Christian convent. Even in *Love Medicine* we meet Pauline/Sister Leopolda as a sadistic figure who abuses her own daughter when Marie comes to the convent in an attempt to construct an identity for herself. Ironically, while searching for her vision within the Christian convent, Marie never realizes that she has in fact encountered there her real mother and in the end defined herself through the conflict with her.

Marie herself is another type of mother, a "super mother," as Tanrisal calls her. In a way, she might be more of a mother than any other character, as she takes care not only of her own children but also of the ones who have been abandoned by their real parents, like June and Lipsha. Although her own identity is undetermined, and although she loses her son and daughter in the same year when they are born, she still never gives up the struggle to keep her family together and to provide both her biological and adopted children with a warm and caring home. Tanrisal emphasizes how, contrary to the Western-European notions of a nuclear family, Native Americans never see biological children as preferred or superior in any way over adopted children.

Lulu, on the other hand, is a "seductive mother," a "goddess of fertility" (Tanrisal) with her nine children, all fathered by different men. She is rejected in the society because of this, but feels neither regret nor shame. Erdrich presents Lulu as an important provider of continuity in the community, and also a provider of certain unity, which she accomplishes through her boys who love her and always stick together: "Lulu managed to make the younger

boys obey perfectly . . . while the older ones adored her to the point that they did not tolerate anything less from anyone else" (*Love Medicine* 85). Moreover, because of this complicated net of affairs, both Lulu and Fleur as her mother connect the community through the bloodline.

June, on the other hand, stands out as the only female *trickster* who constantly fails at performing the mother figure role during her life. Her own sense of identity is seriously shaken up by the fact that she does not know her real parents and that she was raised partially by the housekeeping and feminine adoptive mother Marie, and partially by Eli who familiarizes her more with her masculine side. Yet, as it was explained earlier, June as an adult seems unable to cope properly with her *berdache* upbringing and eventually becomes alienated from her own tradition. As a result of her unusual and wandering life, she does not provide her son King with any motherly attention and affection, and also gives up her second son Lipsha and gives him to Marie to take care of him, just like she took care of June. Unlike the other women, who are more or less comfortable with their fluid and ambiguous *trickster* characteristics and who are able to combine both gender roles in their behavior, June is too uncomfortable with her *berdache* nature; she gets lost in it, and thus also fails to perform as a proper mother figure.

Taking all this into consideration, it can also be noticed that those characters who are familiar with the bloodline on their maternal line (Fleur and Lulu) are more comfortable with their *berdache* nature and have a better, stronger sense of identity, while those who do not know who their mother is (Marie and June) have an uncertain sense of identity and thus have to search for it. Fleur is the only female character who is completely familiar with her ancestry, so it is not surprising that she is also the one who reveals her *berdache/trickster* nature fully, and incorporates those traits through her character and behavior in a strong and confident way.

### 3.4.4. The Tale of Two *Trickster* Sisters

In her critical essay "What about the Sweetheart?: The 'Different Shape' of Anishinabe Two Sisters Stories in Louise Erdrich's *Love Medicine* and *Tales of Burning Love*" Karah Stokes reminds us that Louise Erdrich is a writer of mixed heritage and her novels consequently contain some concepts and character types that can only be recognized when the reader also becomes somewhat familiar with Anishinabe culture. According to Stokes, aside from the plot patterns and the characters that draw on the concepts of the *berdache* and the *trickster* figure, Erdrich also incorporates within her novels two female characters that resemble Oshkikwe and Matchikwewis, two sisters with polar, or opposing, personalities from a cycle of stories told by Anishinabe women. These two characters are, naturally, Marie Kashpaw and Lulu Nanapush.

The names of the sisters from the traditional stories are descriptive: "Oshkikwe means 'young woman' (oshki- means 'young, 'new,' or 'unmarried' and ikwe means 'woman'); as for Matchikwewis, matchi means 'bad'" (Stokes). Furthermore, the younger sister Oshkikwe usually displays the traditional values like modesty, politeness, and common sense, while the older sister Matchikwewis demonstrates the opposite traits, such as greed, rudeness, and impulsiveness, especially in matters of sex. Nevertheless, both sisters are equally loved in these traditional stories.

If the two central female characters from *Love Medicine* are compared to these mythical sisters, it becomes apparent that the family-oriented "super mother" Marie undoubtedly reminds of Oshkikwe, while the sexually assertive "seductive mother" Lulu resembles Matchikwewis. Just like the traditional sisters, Marie and Lulu both have romantic connections with the same man, Nector Kashpaw. Seductive Lulu might be more prone to seduce and lure Nector into an affair both when they are young and older, but Marie does not

pursue him in such a way. He is the one who is perceived as more dominant when they have their first sexual experience in the chapter "Wild Geese." It is interesting how Erdrich uses these two characters to demonstrate that a woman can assume both positions in regard to a man – the dominant or the submissive one. Stookey also notices this polarity between the two women: "the trope of the two cannisters is altogether apt: Marie is indeed the salt in Nector's life, and Lulu is the sugar. . . . Nector is 'greedy' and can 'never have enough of both,' he cannot make the choice between sugar and salt" (42). Yet, regardless of the fact that these women share the same man, they form a partnership with each other to protect the Native tradition after Nector's death. Marie even helps Lulu while she is recovering from her eye surgery, just like a good sister would.

Another link between Lulu and Marie is Lipsha Morrissey. Although he was raised by Marie as a rejected June's son, and, lacking the knowledge of his true ancestry, he sees Marie as a grandmother, he is actually Lulu's grandson. Lulu discloses his real identity to him only later, when he has already reached adulthood, by telling him that he is her grandson, the child of her son Gerry and June Morrissey. Again, the two women act as opposing forces – Marie conceals the truth to protect her adoptive daughter June, while Lulu reveals it and thus assists Lipsha in search for his identity.

Although they seem like two different sides of a coin, they also in a way resemble each other. Barry and Prescott also note that "the two characters mirror one another in their role as mother, in their ability to take risks, in their way of blending past and present, and in their wielding of power in old age." Both women are equally important in the novel and equally present in their own narratives and in the narratives of other characters. The "bad sister" is never rejected or separated from her counterpart just so that the story could teach some kind of a moral lesson. Despite their opposing personalities, they both possess some desirable and some undesirable characteristics, and the reader can identify with both of them. Therefore,

they almost serve as a reminder that the readers themselves can at times easily slip into the role of the *trickster*, sometimes identifying with one side of the story, and sometimes with the other one. Also, "the balance between the two sisters actually works to legitimize female strength" (Stokes). This bond between them does not match the typical assumptions of the Western society about unfaithful men and consequent rivalry between women, and therefore Marie and Lulu's relationship can also be seen as yet another Erdrich's tool for the deconstruction of gender stereotypes.

## Conclusion

Louise Erdrich's novels have attracted and keep attracting a wide range of readers, from lay people to literary scholars. Her contemporary writing is known for the use of multiple narrators whose different perspectives create a unique universe of intriguing characters and tangled relationships. The worldview that she provides in writing is positioned on the verge of two merging cultures, as she is of mixed heritage herself. The novels *Love Medicine* and *Tracks* are primarily set in North Dakota on a fictional reservation. Neither of them has a form of a linear, protagonist-oriented narrative; they both draw on oral narrative strategies of Native American tradition and create storytelling designs that the critics describe as a short story sequence, or a short story cycle. Therefore, they are considered to be written at the "edge" of the genre of the novel.

In these novels, Erdrich portrays a vast variety of characters and uses her narrative style to disrupt some of the existing concepts of fixed identity. Her characters of mixed Native American and Catholic heritage often walk the lines between multiple worlds, which enables the readers to understand the idea of fluid ethnic identity. However, the emphasis is also on the fluidity of gender, as the familiar Western stereotypes about gender roles are questioned and reappropriated to raise awareness of diverse possibilities of a person's identity within patriarchal societies and structures.

In order to create these fluid identities, Erdrich draws on Native American tradition and its gender roles, which are rooted in powerful mythic figures full of oppositions and contradictions, such as the *berdache* and the *trickster*. The *berdache* figure can be depicted as a person who is in some way transgendered, normal in physical anatomy, but tends to apply the dress, occupations and/or behaviors of the opposite sex to affect a change in their gender status. It is closely related to the figure of *trickster*, who possesses no specific fixed form, can

assume the form of various animals, or even supernatural beings, but is primarily a being of undetermined proportions, fore-shadowing the shape of a man. The behavior of both these figures is usually considered antisocial because it transcends the usual and comfortable social restrictions. They have an ability to live in-between categories, outside the structures of society, in the liminal or marginal spaces. They are independent of any boundaries, temporal or spatial, and are always ambiguous – whether in regard to their sexual status, age, position between individuality and community, life and death, creativity and destruction, good and evil, or human and animal/spiritual dualism. As such, *berdaches* and *tricksters* often enjoy privileged freedom unavailable to those who unconditionally follow societal codes.

Furthermore, Erdrich's work itself can be characterized as a *trickster* discourse – a set of multiple narratives that play with oppositions in which the *trickster* figure is not only a character but also a narrative device. By employing this narrative technique, Erdrich manages to blur various boundaries – those between cultures and genders, between self and other, reality and fantasy, and even the story and audience, as the readers sometimes must decide which narrators are more credible. Moreover, this sort of storytelling is free of any moral restrictions and instead offers a possibility of an open communication between the teller, the tale, and the audience.

This paper has analyzed several female *trickster* characters from Erdrich's North Dakota Cycle – Fleur Pillager from *Tracks* and June Morrissey, Lulu Nanapush, and Marie Kashpaw from *Love Medicine*. All of these women are capable of transgenderation as they incorporate within their lives both the feminine and the masculine traits, be it in their physical appearance or behavior. Fleur is almost a mythic character, with a body strong as a man's, but with alluring feminine energy in her core. She is a shape-shifter also, resembling at the same time the wolf, the bear, and the lake monster, all powerful creatures from Native tradition. Fleur is a highly independent individual; she is a hunter, a fighter, a healer, a lover, a mother,

a spirit and a woman – all in one. Her unique figure inspires both fear and awe within the community.

Fleur's daughter Lulu carries on in her blood some of the *trickster* traits, as well. She is an irresistible seductress of profound sexual power, which she displays openly and fearlessly. She alone is a mother of nine children, all by different fathers, and as such plays an important role in repopulating the reservation and contributing to the preservation of Native bloodlines. Marie is yet another manly-hearted woman, playing a kind of counterpart to Lulu. Although she is Pauline's daughter, her identity is unknown to her, and during her younger years something inside her drives her to seek out a vision and create her own identity in a Catholic convent. However, she abandons this path and becomes a wife of a tribal chairman, following a more traditional path of a Native woman. She slips easily from one identity to another, which gives her some prominent *trickster* qualities. Lulu and Marie, on the other hand, bear a striking resemblance to Oshkikwe and Matchikwewis, a polar pair of sisters from traditional Anishinaabe lore. Lulu plays her part as the older one, Matchikwewis, representing traits such as impulsiveness and greed, whereas Marie plays the younger one, Oshkikwe, representing traditional values like politeness and modesty. These women are linked to each other in various ways throughout their lives, and are always equally loved and important in status.

June is a woman to whom identity is elusive, partially as a result of the lack of knowledge about her real blood relatives. Adopted by Marie and raised by Eli, she receives a *berdache* upbringing, but later in life also attempts to perform some traditional feminine roles of a wife and a mother. June tries, albeit unsuccessfully, to identify herself with some of the gender roles and the surrounding traditions, seeking out marginal ways of living. Yet, she is not completely comfortable with her *berdache* existence either; her fragmented identity causes chaos in her life, and estrangement from her tradition eventually leads to her own death.



Although she is physically present only in the first chapter of *Love Medicine*, June continues to manifest as an ambiguous, absent presence throughout the entire novel, as other characters create their stories which turn out to be related to June in one way or another.

All these women, with the exception of Fleur, are at least partially unaware of their true ancestry; yet, it is only June who fails at performing her *berdache* and *trickster* role, whereas other women turn this identity to their advantage. Through these female *trickster* characters, Erdrich (de)constructs the existing stereotypes about Native women and gender roles in general, and offers a new, more flexible picture. Her *tricksters* manage to play the roles of victims and winners, promiscuous women and saints, humans and spirits at the same time. In this way, they move as liminal figures on the borderlines between oppositions; they escape signification within fixed sex-related stereotypes, and thereby raise questions about socially accepted patterns of thought and action. Behind this skill hides the characters' ability to overcome and transcend the boundaries of their physical bodies, as they not only relate the stories within a single novel, or the two novels they appear in, to each other but also connect the community fictionalized in them into a whole, thus helping their Native American tradition to survive.

## Works Cited

- Adamson Clarke, Joni. "Why Bears Are Good to Think and Theory Doesn't Have to be Murder: Transformation and Oral Tradition in Louise Erdrich's *Tracks*." *Studies in American Indian Literature* 4.1 (1992): 28-43. Print.
- Babcock, Barbara. "A Tolerated Margin of Mess': Trickster and His Tales Reconsidered." *Critical Essays on Native American Literature*. Ed. Andrew Wiget. Boston: G.K. Hall & Co., 1985. 153-85. Print.
- Baker Barry, Nora. "Fleur Pillager's Bear Identity in the Novels of Louise Erdrich." *Studies in American Indian Literatures* 12.2 (2000): 24-38. Print.
- Ballinger, Franchot. "Coyote He/She Was Going There: Sex and Gender in Native American Trickster Stories." *Studies in American Indian Literatures* 12.4 (2000): 15-43. Print.
- Barak, Julie. "Blurs, Blends, Berdaches: Gender Mixing in the Novels of Louise Erdrich." *Studies in American Indian Literatures* 8.3 (1996): 49-62. Print.
- Barry, Nora, and Mary Prescott. "The Triumph of the Brave: Love Medicine's Holistic Vision." *Critique* 30.2 (1989): 123-38. Project MUSE. Web. 13 Mar. 2005.
- Beidler, Peter G., and Gay Barton. *A Reader's Guide to the Novels of Louise Erdrich*. Columbia and London: University of Missouri Press, 1999. Print.
- Brehm, Victoria. "The Metamorphoses of an Ojibwa Manido." *American Literature* 68.4 (1996): 677-706. Print.
- Cox, Jay. "Dangerous Definitions: Female Tricksters in Contemporary Native American Literature." *Wicazo SA Review* 5.2 (1989): 17-21. Print.
- Erdrich, Louise. *Love Medicine*. Toronto, New York, London, Sydney, Auckland: Bantam Books, 1984. Print.
- . *Tracks*. New York: Henry Holtand Company, 1988. Print.
- Farrell, Susan. "Erdrich's Love Medicine." *Explicator* 56.2 (1998): 109-13. EBSCO. Web. 29 Jan. 2004.
- Hassell Hughes, Sheila. "Tongue-tied: Rhetoric and Relation in Louise Erdrich's *Tracks*." *MELUS* 25.3/4 (2000): 87-116. Print.
- Landay, Lori. "Betwixt and Between: the Trickster and Multiculturalism." *American Quarterly* 48.3 (1996): 542-49. Print.

- Radin, Paul. "The Trickster: Prefatory Note." *Literature of the American Indians: Views and Interpretations*. Ed. Abraham Chapman. New York: The New American Library, 1975. 253-56. Print.
- Rosenthal, Caroline. *Narrative Deconstructions of Gender in Works by Audrey Thomas, Daphne Marlatt, and Louise Erdrich*. New York: Camden House, 2003. Print.
- Sanders, Karla. "A Healthy Balance: Religion, Identity, and Community in Erdrich's *Love Medicine*." *MELUS* 23.2 (1998): 129-56. Project MUSE. Web. 13 Mar. 2005.
- Smith, Jeanne Rosier. "Transpersonal Selfhood: The Boundaries of Identity in Louise Erdrich's *Love Medicine*." *Studies in American Indian Literatures* 3.4 (1991): 13-26. Print.
- . *Writing Tricksters: Mythic Gambols in American Ethnic Literature*. Berkeley, Los Angeles, London: U of California P, 1997. Print.
- Stokes, Karah. "What about the Sweetheart?: The 'Different Shape' of Anishinabe Two Sisters Stories in Louise Erdrich's *Love Medicine* and *Tales of burning Love*." *MELUS* 24.2 (1999): 89-106. Project MUSE. Web. 13 Mar. 2005.
- Stookey, Lorena Laura. *Louise Erdrich: A Critical Companion*. London: Greenwood Press. 1999. Print.
- Tanrisal, Meldan. "Mother and Child Relationships in the Novels of Louise Erdrich." *American Studies International* 35.3 (1997): 67-80. EBSCO. Web. 29 Jan. 2004.
- Van Dyke, Annette. "Of Vision Quests and Spirit Guardians: Female Power in the Novels of Louise Erdrich." *The Chippewa Landscape of Louise Erdrich*. Ed. Allan Richard Chavkin. Tuscaloosa and London: The U of Alabama P, 1999. Print.
- Vizenor, Gerald. *The Trickster of Liberty: Tribal Heirs to a Wild Baronage (Emergent Literatures)*. Minneapolis: U of Minnesota P, 1988. Print.
- . "Trickster Discourse: Comic Holotropes and Language Games." *Narrative Chance: Postmodern Discourse on Native American Indian Literatures (American Indian Literature and Critical Studies, Vol 8)*. 1989. Norman: U of Oklahoma P, 1993. 187-213. Print.
- Wiget, Andrew. "His Life in His Tail: The Native American Trickster and the Literature of Possibility." *Redefining American Literary History*. Ed. LaVonne A. Brown Ruoff and Jerry W. Ward. New York: MLA, 1990. 83-97. Print.